

# THE APPLICATION OF PLASMA-ARC TECHNOLOGY FOR THE PRODUCTION OF CALCIUM CARBIDE

L.J. Erasmus

formerly Principal Engineer, Mintek  
Randburg, South Africa

## ABSTRACT

A detailed thermodynamic study of the carbothermic production of calcium carbide at elevated temperatures was performed to broaden the fundamental understanding of the chemistry involved during the thermal production of calcium carbide. This was followed by an experimental investigation to prove the validity of the simulations and to demonstrate the feasibility of plasma-arc technology for the production of calcium carbide.

The agreement between the simulations and the experimental results was excellent. The experimentation demonstrated that the semi-continuous production of calcium carbide in a plasma-arc furnace is viable. A maximum grade of 93 per cent  $\text{CaC}_2$  was achieved during batch tests, while grades above 80 per cent  $\text{CaC}_2$  were realised during semi-continuous operation. The results also suggest that the calcium units could be recirculated after acetylene generation.

## INTRODUCTION

The first calcium carbide, commonly known as carbide, was produced accidentally in 1802 when Robert Hare, an American scientist, tried to melt lime and magnesia on an anthracite bed. The first commercial carbide furnace was built in 1895 by the Willson Aluminium Company<sup>1</sup>. The continuous process in a submerged-arc furnace was developed using excess lime in the carbon/lime mixture to lower the melting temperature of the carbide product. Commercial carbide contains about 80 per cent  $\text{CaC}_2$ , and 10 to 15 per cent  $\text{CaO}$  with the balance consisting of metal oxide impurities such as  $\text{Al}_2\text{O}_3$  and  $\text{SiO}_2$  associated with the raw materials.

The different phases in a calcium carbide producing furnace are the gas phase ( $\text{CO}$  and  $\text{Ca}$ ), the carbide phase ( $\text{CaC}_2$ , excess  $\text{CaO}$  and the metal oxide impurities), the metal phase ( $\text{Fe}$  and about 15 per cent  $\text{Si}$ ) and sometimes a solid carbon phase. A detailed thermodynamic study of the carbothermic production of calcium carbide at elevated temperatures was carried out to clarify the process chemistry, and to establish the relevant governing equilibria in a carbide-producing furnace under different operating conditions.

The initial batch tests were performed in a 50 kVA direct-current (d.c.) transferred plasma-arc furnace, operated at 40 kW. Two semi-continuous campaigns were performed in two different plasma-arc furnaces, rated at 200 kVA and 3.2 MVA and operated at around 140 kW and 500 kW respectively. The feed consisted of calcined limestone, dehydrated calcium hydroxide (calcium hydroxide is obtained during the generation of acetylene from industrial calcium carbide), and anthracite.

## THEORETICAL CONSIDERATIONS

The formation of calcium carbide in the solid state is suggested by Wiik *et al* to be as follows:<sup>2</sup>

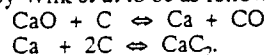

Liquid-phase formation of carbide is described by the one-step reaction:<sup>3</sup>



The major side-reactions are the thermal dissociation of calcium carbide:

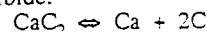

and the reaction between calcium carbide and calcium oxide:

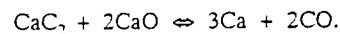

Other side-reactions involve the carbothermic reduction of impurities associated with the raw materials. Iron oxides and silicon oxide are reduced, and accumulate as a ferrosilicon phase or as carbides in the calcium carbide product. Magnesium oxide is reduced to magnesium vapour, while aluminium oxide is more difficult to reduce and accumulates to a large extent in the carbide product.

## SIMULATION OF THE CARBIDE PROCESS

A thermodynamic simulation of the carbide production process was performed using a thermodynamic simulator program 'PYROSIM' developed at Mintek.<sup>4</sup> The thermodynamic data were obtained from McGill University's F\*A\*C\*T data-base.<sup>5</sup> A major constraint is the lack of thermodynamic data for several compounds at temperatures above 2000 K. Most of the thermodynamic data used were extrapolated. More specifically, the reaction between anthracite and calcined limestone was simulated (the chemical analyses of these raw materials are shown in Table I). The effects of temperature and carbon stoichiometry on the product grade were assessed. The carbon stoichiometry, expressed as the percentage carbon in the feed, which was used throughout as a quantitative measure of the carbon added, is defined as follows:

$$\text{Percentage C in feed} = \frac{\text{C in feed, kg}}{(\text{C} + \text{CaO}) \text{ in feed, kg}} \times 100.$$

The carbon stoichiometry was varied in the range between 34 and 46 per cent while the temperature was varied between 1700 and 2500°C. An increase in the carbide grade is effected by an increase in temperature as illustrated in Figure 1. The production of carbide, containing 80 per cent  $\text{CaC}_2$ , is possible at 2000°C when the percentage carbon in the feed is 37 per cent or greater. The grade increases to 95 per cent  $\text{CaC}_2$  at 2300°C. Excess carbon in the feed (above 40 per cent) does not

increase the conversion to any marked extent, whereas a shortage of carbon in the system leads to a dramatic increase in calcium vapour losses. The expected calcium vapour lost to the gas phase is shown in Figure 2. Calcium vapour losses are negligible below 2000°C, but increase to 19 per cent at 2500°C with more than the stoichiometric carbon addition (more than 40 per cent carbon in the feed). However, the losses increase to 45 per cent at 2500°C when the carbon in the feed is 34 per cent, i.e. when a carbon shortage prevails.

The specific energy requirement is shown in Figure 3. The specific energy requirement reaches a minimum of about 3.7 kWh per kilogram of  $\text{CaC}_2$  at 2000°C (80 per cent  $\text{CaC}_2$  in the carbide phase), independent of the feed composition, in the range simulated. This appears to be the optimum operating point from the viewpoint of both grade and energy requirements.

As expected, more than 80 per cent of the  $\text{Al}_2\text{O}_3$  stays in the carbide phase as calcium aluminates at temperatures below 2000°C. This figure decreases to between 20 and 50 per cent at 2300°C, depending on the carbon stoichiometry. Most of the silicon stays in the carbide phase as silicon carbide and calcium silicate, whereas most of the magnesium (92 per cent) and manganese (99 per cent) are lost into the vapour phase at temperatures above 2000°C.

Table I: Raw material analyses, % by mass

Constituent	Anthracite ash	Calcined limestone	Dehydrated $\text{Ca}(\text{OH})_2$
CaO	10.97	93.93	80.08
$\text{SiO}_2$	44.88	1.05	4.69
$\text{Al}_2\text{O}_3$	28.77	0.33	2.01
$\text{Fe}_2\text{O}_3$	8.24	0.30	1.37
MgO	1.19	1.74	0.30
C		0.30	2.48
$\text{H}_2\text{O}$		1.63	9.16
% Dehydration			64.41

% by mass	Anthracite
Fixed carbon	72.9
Volatiles	7.67
Moisture	4.60
Ash	14.83

## EXPERIMENTAL WORK

The experimental work was performed in d.c. transferred plasma-arc furnaces rated at 50 kVA, 200 kVA, and 3.2 MVA.

The reaction zone in the furnace is heated by an electrically generated plasma-arc (i.e. argon plasma during warm-up and carbon monoxide plasma during normal operation). The plasma-arc is directed from a graphite electrode, or cathode, into the reaction crucible with the accompanying transfer of thermal energy to the reaction zone, i.e. the surface of the molten carbide. The maintenance of the temperature in the reaction zone above the minimum reaction temperature affects the required endothermic reduction reaction.

## 1 Experimental equipment

The experimental work started with batch tests in a sealed 50 kVA plasma-arc furnace. The furnace had an inside diameter of 200 mm and a useful volume of about 6l. The success of the initial work was very encouraging, and was followed by two semi-continuous smelting campaigns employing a 200 kVA and a 3.2 MVA plasma-arc furnace. A schematic diagram of the 3.2 MVA furnace is shown in Figure 4.

The reaction in the 200 kVA furnace was contained in a graphite crucible with an inside diameter of 400 mm and a wall thickness of 50 mm, backed with magnesia refractory. The water-cooled conical roof was lined with a SiC castable. The 3.2 MVA furnace was of similar design. The furnace inside diameter was 900 mm, lined with graphite bricks, and also backed with magnesite refractory. The roof was also lined with a SiC castable.

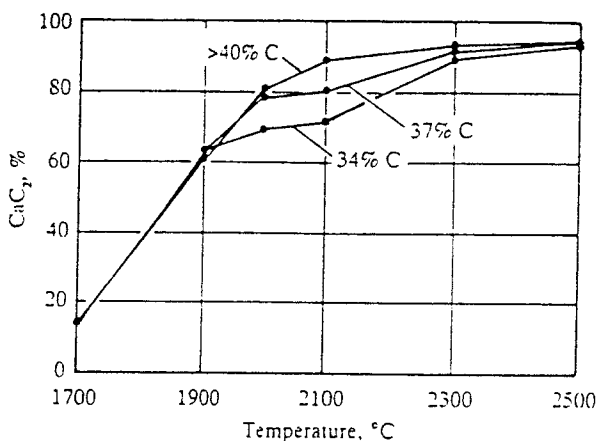

Fig. 1. Carbide grade versus operating temperature

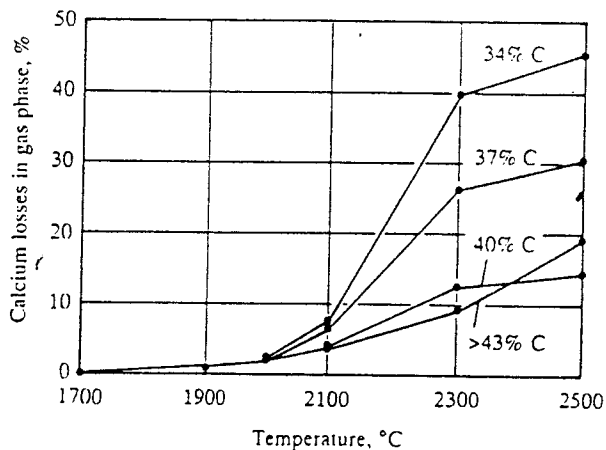

Fig. 2. Calcium vapour losses

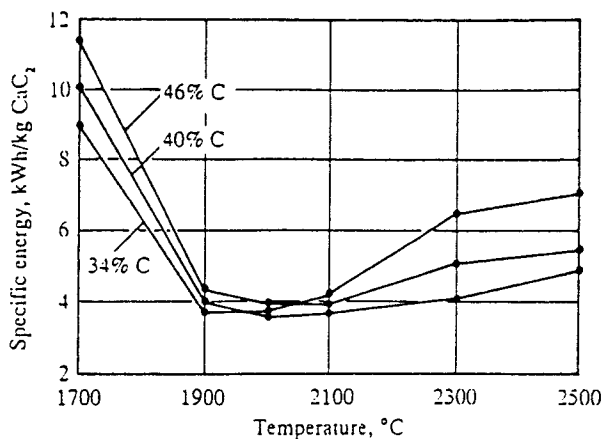

Fig. 3. Specific energy requirement

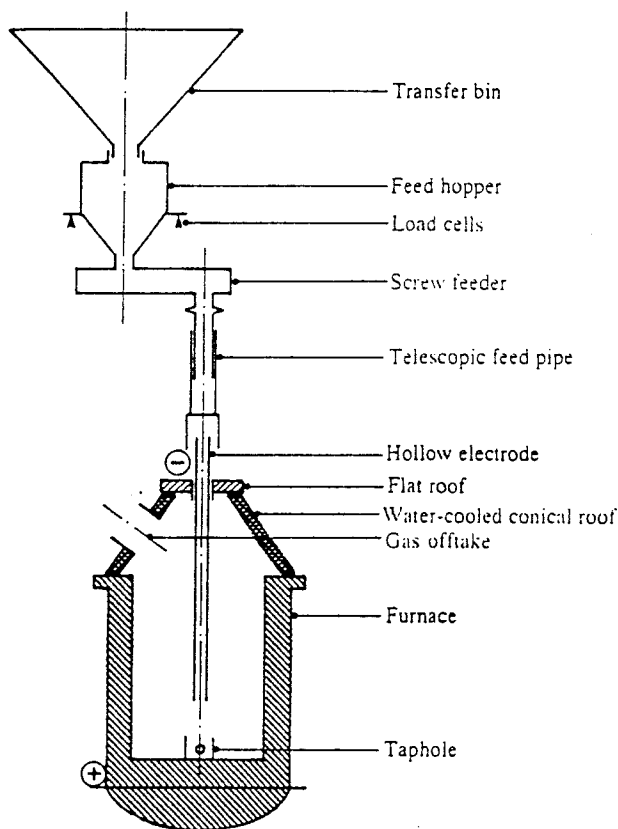

Fig. 4. The 3.2 MVA plasma-arc furnace

## Method

Low-grade ferrosilicon (25 per cent Si) was melted in the bottom of the furnace to create the initial molten bath. Feed material was supplied into the molten bath either through a side feed port (employed during testwork on the two small furnaces) or through the centre of a hollow graphite electrode (employed during testwork on the 3.2 MVA furnace). The feed rate was calculated from the specific energy requirement and the net energy input into the furnace after consideration of heat losses. The heat

losses from the furnace were calculated using measured temperature differentials through the sidewalls and temperature increases of the water in the cooling circuits.

Calcined limestone and anthracite (between 1 and 6 mm) were employed for both the batch tests and the 200 kVA plasma campaign, while dehydrated calcium hydroxide (the byproduct from an acetylene generator using industrial carbide) was employed as the calcium source during the 3.2 MVA campaign. The calcium hydroxide was briquetted, dehydrated, crushed, and screened into a similar size range as the lime used on the small furnace. However, this dehydrated material tended to deprecitate. Chemical analyses of the raw materials are given in Table I.

The CaO content of the burnt lime was 93 per cent. The degree of dehydration of the dehydrated calcium hydroxide varied between 60 and 70 per cent. The increase in impurities between burnt lime and calcium hydroxide is obvious from this table. This rise in impurities can be attributed to the metal oxides in the ash of the anthracite, which accumulate in the carbide phase. The recirculation of calcium hydroxide from acetylene generators can currently be practised only to a limited extent for this very reason.

The calcium carbide was removed from the plasma-arc furnaces at set intervals into a metal tapping ladle. A spoon sample was taken for chemical analysis during tapping. The fumes were burned in a combustion chamber situated directly above the water-cooled gas off-take in the roof. The solids were collected in a reverse-pulse bag plant, removed, weighed, and analysed.

## The 50 kVA Batch Tests

The 10 kg batches were pre-mixed and fed after the furnace had been pre-heated for about one hour. The furnace was operated at about 40 kW. The carbide, embedded in unreacted feed material, was allowed to cool down inside the furnace after each test before being removed. The results for the five batches of feed are given in Table II and compared with the calculated values in Figure 5. Carbide grades of up to 93 per cent were achieved. The agreement with the grades predicted at 2100°C is excellent, suggesting that the reaction temperature in the furnace must have been around 2100°C.

## The Semi-continuous Campaigns

Five recipes were tested during the semi-continuous smelting campaigns. A summary of the calculated product composition and energy requirement at 1900°C for the first recipe (34 per cent carbon in the feed) and at 2000°C and 2100°C respectively for the other recipes is shown in Table III. The first recipe was used to pre-heat the furnace. The lower grade enabled easier tapping of the carbide product from the furnace, allowing the refractories to reach temperature equilibrium.

These calculations clearly show the effect of the larger percentages of impurities in the dehydrated Ca(OH)<sub>2</sub> (compared with the lime) on the grade and energy requirement. Similar product grades are predicted at elevated temperatures (at 2100°C, with extra reductant addition), but with a substantial increase in the energy requirement when the purity of the starting materials is

lower. This can be explained by the extra energy required to reduce these impurities so that they either collect in the ferrosilicon phase or are removed from the carbide into the vapour phase.

Table II: The 50 kVA experimental details

Batch no.	Feed		Carbide produced		
	Mass kg	C %	Mass kg	Grade	
				l/kg*	CaC <sub>2</sub> , %
1	10.0	34	4.49	255	69.2
2	10.0	40	3.07	316	86.6
3	10.0	40	3.50	321	88.0
4	10.0	44	3.29	343	93.1
5	10.0	47	2.60	335	90.9

\* l/kg: litres of acetylene per kilogram carbide.

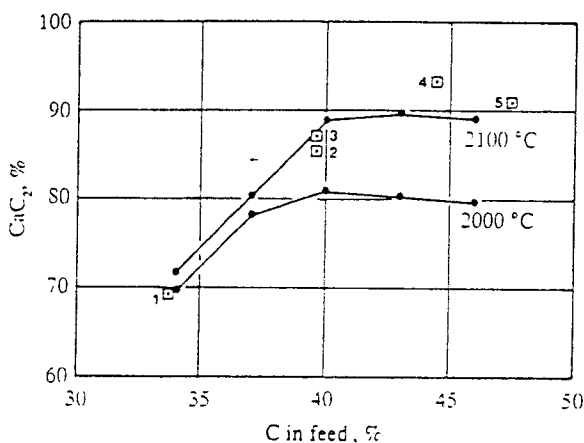

Fig. 5. Comparison between the simulations and the 50 kVA results

## RESULTS AND DISCUSSION

The experimental details and results for each recipe are summarised in Tables IV and V.

The tapping temperatures shown in the tables were measured with an optical pyrometer. The gas yield determinations, in litres acetylene per kg carbide, were performed during the campaigns. Detailed chemical analyses were performed after completion of the campaigns, and are shown in Table VI. The product grade for the first recipe was in good agreement with the calculated values. The calculated and experimental results for the other four recipes are compared in Figure 6. The product grades were in the band predicted between 2000°C and 2100°C, which is in good agreement with the measured temperatures, thus confirming the validity of the simulations.

It is significant that the grades (percentage CaC<sub>2</sub> in the carbide) achieved with recipes 2 and 3 are between 5 and 10 per cent better than those obtained in the industrial submerged-arc production of carbide using the same raw materials. This can be attributed to the higher operating temperature attainable in the plasma-arc system.

As previously noted, the recirculation of calcium hydroxide after acetylene generation is limited during a submerged-arc operation. However the results achieved in the plasma-arc furnace are similar to those obtained with lime. The energy consumption was higher when dehydrated Ca(OH)<sub>2</sub> was employed (depending on the purity of this recirculation stream). The best carbide produced with dehydrated calcium hydroxide contained 87 per cent CaC<sub>2</sub>, similar to the experimental results obtained with lime, which are better than those obtained in normal industrial production. The chemical analyses of the Ca(OH)<sub>2</sub> (obtained after acetylene generation) from the carbide samples produced during the plasma-arc campaigns are shown in Table VI. These results serve to further illustrate that the recirculation of calcium units is a viable option in a plasma-arc furnace.

The chemical analyses of the calcium hydroxide (obtained after acetylene generation) from carbide produced with recipe 1, at an operating temperature below 2000°C, yielded results similar to those obtained in the industrial process (Table I, last column) using the same raw materials. A slight increase in the average impurity levels was experienced compared with those in the initial lime being used for the second and third recipes. As previously noted, the Ca(OH)<sub>2</sub> employed during recipes 4 and 5 was from acetylene generators, with relatively high impurity levels. The analysis after plasma processing showed that this material can be utilised to produce carbide in a plasma-arc furnace without further build-up of impurities. In fact, when the operating temperatures were above 2000°C in the plasma-arc furnace, the impurity levels displayed a marked decrease when compared to calcium hydroxide obtained after industrial carbide production. This was effected by volatilization (as sub-oxides or metal vapours) of most of these

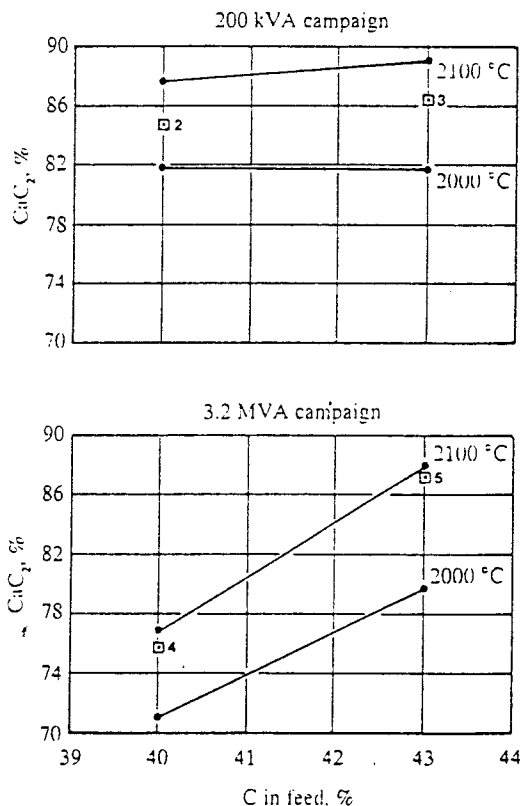

Fig. 6. Comparison between the simulations and campaign results

Table III: Calculated product composition and energy requirements

Parameter	Anthracite and lime used during the 200 kVA campaign					Dehydrated Ca(OH) <sub>2</sub> and anthracite used during the 3.2 MVA campaign			
	34	40		43		40		46	
Carbon in feed, %	34	40		43		40		46	
Temperature, °C	1900	2000	2100	2000	2100	2000	2100	2000	2100
Grade, % CaC <sub>2</sub>	62.5	81.8	87.5	81.7	89.0	71.0	76.8	79.7	87.9
Energy requirement, kWh/kg carbide	2.37	3.00	3.39	3.07	3.50	3.65	4.82	3.99	4.65

Table IV: Experimental details of the 200 kVA campaign

Recipe no.	Feed		Operating power kW	Carbide produced				Net energy consumption kWh/kg carbide
	Mass kg	C %		Mass kg	Tapping temp. °C	Grade		
						l/kg	CaC <sub>2</sub> , %	
1	262.0	34	99	121.0	1880	240	65.8	2.53
2	349.3	40	138	194.4	2062	309	84.7	3.90
3	807.0	43	138	448.2	2115	315	86.3	4.30

Table V: Experimental details of the 3.2 MVA campaign

Recipe no.	Feed		Operating power kW	Carbide produced				Net energy consumption kWh/kg carbide
	Mass kg	C %		Mass kg	Tapping temp. °C	Grade		
						l/kg	CaC <sub>2</sub> , %	
4	4819.2	40	480	2697	1968	276	75.7	4.15
5	3556.9	46	463	1620	2059	318	87.2	6.05

\* Net energy consumption: heat losses from the furnace are excluded.  
+ l/kg: litres of acetylene per kilogram carbide.

Table VI: Product calcium oxide analyses

Recipe no.	Analytical results, % by mass					
	CaO	SiO <sub>2</sub>	Fe <sub>2</sub> O <sub>3</sub>	Al <sub>2</sub> O <sub>3</sub>	MgO	C
1	73.66	3.32	9.58	0.98	1.09	2.31
2	82.22	1.41	4.95	1.44	<0.2	2.15
3	81.12	2.46	4.57	1.23	<0.2	2.62
4	82.23	1.92	2.30	2.25	0.39	1.96
5	83.34	1.75	2.55	1.40	<0.2	2.54

Note: The chemical analyses for the impurities in the carbide samples were obtained after acetylene generation.

impurities at the very high temperatures prevailing in the arc-attachment area of the plasma-arc furnace. The SiO<sub>2</sub> level dropped from 4 to below 2 per cent, while the Al<sub>2</sub>O<sub>3</sub> decreased slightly to below 2 per cent. Iron contamination was caused by oxygen lancing to tap the furnace.

The furnace was dug out after completion of a campaign. The SiC-lined roofs showed little chemical attack, while the graphite lining was protected by a frozen layer of carbide. The electrode consumption was around 0.7 kg graphite per hour of operation at around 500 kW. The electrodes tended to be eroded from the inside, close to the tip. Erosion of the electrode in addition to arcing could have taken place by physical wear as the feed material moved through the electrode, and also by chemical means with small amounts of carbide being formed on the inside surface of the electrode.

## CONCLUSIONS

High-grade carbide (93 per cent) could be produced during batch operation on the 50 kVA plasma-arc furnace. Two follow-up experimental campaigns were performed, employing a 200 kVA and a 3.2 MVA plasma-arc furnace operated at 140 kW and 500 kW respectively. The semi-continuous production of carbide using lime and dehydrated calcium hydroxide was demonstrated, with the average carbide grades (between 85 and 87 per cent) above those produced in industrial carbide operations.

The higher operating temperatures prevented the build-up of unwanted impurities in the carbide. The recirculation of the calcium units to the carbide-producing furnace would be a possible advantage of the plasma route.

The excellent agreement between the experimental results and the simulation predictions substantiates the potential usefulness of the simulation package for optimizing operation and predicting the influence of various parameters on the operation.

#### ACKNOWLEDGEMENT

The author wishes to thank Mintek and AECI for permission to publish this paper.

#### REFERENCES

1. J.T. Morehead and G. de Chalmot, "The Manufacture of Calcium Carbide". The Journal of the American Chemical Society, Vol. 18, No. 4, April 1896, pp. 311 - 331.

2. K. Wiik, O. Raaness, and S.E. Olsen, "Formation of Calcium Carbide From Calcium Vapour and Carbon". Scandinavian Journal of Metallurgy, Vol. 13, 1983.
3. N. Torigai, "Calcium Carbide Formation Reaction in the Molten Phase". Kogyo Kagaku Zassai, 1966, pp. 1347 - 1354
4. R.T. Jones, "Computer Simulation of Pyrometallurgical Processes". APCOM 8 Proceedings of the Twentieth International Symposium on the Application of Mathematics and Computers in the Minerals Industries, Vol. 1, Metallurgy, South African Institute of Mining and Metallurgy, Johannesburg.
5. F\*A\*C\*T thermodynamic database, Therfact, 400 Berwick Avenue, Mont-Royal, Quebec, Canada H3R 1Z8.