

Country

SOUTH AFRICA

P A T E N T
S P E C I F I C A T I O N

Application Number

96/5134

Title

THE PROCESSING OF ZINC BEARING MATERIALS

Filing Date

15 JUNE 1996

Based on

SOUTH AFRICAN PROVISIONAL PATENT NO. 95/4963

Applicant

MINTEK

INVENTORS

NICHOLAS ADRIAN BARCZA
ALBERT FRANCOIS SIMON SCHOUKENS
GLEN MICHAEL DENTON

McCALLUM RADEMEYER & FREIMOND

INTELLECTUAL PROPERTY LAW, PATENTS AND TRADE MARKS

REF: P.17296

REPUBLIC OF SOUTH AFRICA
PATENTS ACT, 1978

AND ACKNOWLEDGEMENT OF RECEIPT
(Section 30(1) — Regulation 22)

The grant of a patent is hereby requested by the undermentioned applicant on the basis of the present application filed in duplicate.

| |
|--|
| Revenue Stamps or Revenue Franking Machine Impression |
| OFFICIAL DATE STAMP |

OFFICIAL APPLICATION NO.

| | | |
|----|----|--------|
| 21 | 01 | 965134 |
|----|----|--------|

FULL NAME(S) OF APPLICANT(S)

| | |
|----|--------|
| 71 | MINTEK |
|----|--------|

ADDRESS(ES) OF APPLICANT(S)

| |
|---|
| 200 HANS STRIJDOM DRIVE RANDBURG REPUBLIC OF SOUTH AFRICA |
|---|

TITLE OF INVENTION

| | |
|----|--|
| 54 | THE PROCESSING OF OF ZINC BEARING MATERIALS |
|----|--|

PRIORITY IS CLAIMED AS SET OUT ON THE ACCOMPANYING FORM P.2.

The earliest priority claimed is South African Provisional Patent Application No. 95/4963 filed 15 June 1995

~~THIS APPLICATION IS FOR A PATENT OF ADDITION TO PATENT APPLICATION NO.~~

| | | |
|----|----|--|
| 21 | 01 | |
|----|----|--|

THIS APPLICATION IS ACCOMPANIED BY:

| |
|--|
| |
|--|

- | | |
|----|--|
| XX | 1 A single copy of a provisional or two copies of a complete specification of32..... pages |
| XX | 2 Drawings of4..... sheets. (Formal/Informal). |
| XX | 3 Publication particulars and abstract (Form P.8. in duplicate) |
| XX | 4 A copy of Figure2..... of the drawings (if any) for the abstract. |
| XX | 5 Assignment of invention. |
| XX | 6 Certified priority document(s) — State number. |
| XX | 7 Translation of the priority document(s). |
| XX | 8 An assignment of priority rights. |
| XX | 9 A copy of the Form P.2. and the specification of S.A. Patent Application No. |
| XX | 10 A declaration and power of attorney on Form P.3. |
| XX | 11 Request for ante-dating on Form P.4. |
| XX | 12 Request for classification on Form P.9. |
| XX | 13 Form P.2. in duplicate. |

| | | |
|----|----|---------|
| 21 | 01 | 95/4963 |
|----|----|---------|

| | |
|----|---|
| 74 | ADDRESS FOR SERVICE: McCALLUM, RADEMEYER & FREIMOND, P.O. BOX 1130, RANDBURG, 2125. |
|----|---|

Dated this 15th day of JUNE 1996

McCallum, Rademeyer & Freimond

 McCALLUM, RADEMEYER & FREIMOND
 APPLICANT'S PATENT AGENTS

| |
|--|
| REGISTRAR OF PATENTS, DESIGNS, TRADE MARKS AND COPYRIGHT |
| Received |
| Official Date Stamp 1996 -06- 18 |
| REGISTRAR VAN PATENTE, MODELE, HANDELSMERKE EN OUTEURSREG |
| REGISTRAR OF PATENTS |

REPUBLIC OF SOUTH AFRICA
PATENTS ACT, 1978

COMPLETE SPECIFICATION

(Section 30(1) — Regulation 28)

OFFICIAL APPLICATION NO

| | | |
|----|----|---------|
| 21 | 01 | 96/5134 |
|----|----|---------|

INTERNATIONAL CLASSIFICATION

| | |
|----|--------|
| 51 | C 22 B |
|----|--------|

LOGGING DATE

| | |
|----|--------------|
| 22 | 15 JUNE 1996 |
|----|--------------|

FULL NAME(S) OF APPLICANT(S)

| | |
|----|--------|
| 71 | MINTEK |
|----|--------|

FULL NAME(S) OF INVENTOR (S)

| | |
|----|--|
| 72 | NICHOLAS ADRIAN BARCZA ALBERT FRANCOIS SIMON SCHOUKENS GLEN MICHAEL DENTON |
|----|--|

TITLE OF INVENTION

| | |
|----|--|
| 54 | THE PROCESSING OF ZINC BEARING MATERIALS |
|----|--|

BACKGROUND OF THE INVENTION

5

This invention relates generally to the reaction of zinc bearing materials with a reducing agent in a d.c. arc furnace in order to recover zinc via a vapour phase, and produce a disposable slag.

10

The invention may be applied to recover zinc from zinc bearing secondary materials, or for the treatment of zinc ores and/or primary oxidic zinc concentrates.

15

Secondary materials such as lead blast furnace slags from lead smelting, Imperial Smelting Furnace (ISF) slags from zinc/lead smelting, electric arc furnace (EAF) dusts produced during the production of carbon steel from scrap, electrolytic zinc-plant residues or leach-process residues, and drosses which contain zinc and lead, are processed primarily for environmental and recycling reasons. The invention may be used for the treatment of these materials.

20

Primary oxidic zinc concentrates and/or zinc ores which are high in silica and therefore also difficult to leach economically, are also amenable to treatment by the method of the invention.

25

5 Technology exists for treating most of these materials to produce saleable products and environmentally acceptable final slags or residues (eg Waelz kiln, Elkem and Tetronics processes). Some of the known processes have experienced technical difficulties or are economically viable only at very large throughputs (more than 50kt of zinc bearing material per annum). The latter
10 factor has led to the establishment of centralised processing facilities controlled by a few large companies and this may place the producers of the secondary materials at a disadvantage.

15 Although environmental considerations are a primary motivating factor dictating the processing of these zinc-bearing secondary materials, it should be borne in mind they contain from 10% to 40% zinc oxide and are a potential resource for the recycling and recovery of zinc.

The use of a three-phase a.c. slag-resistance furnace instead of a d.c. arc furnace for the fuming of zinc and lead has a number of drawbacks. Accurate control of the CO:CO₂ ratio in the furnace gas and of additions of reductant to the reaction zone are not easily achieved, while a power constraint is imposed by the prevailing electrical resistivity of the slag. Flux additions may be required to achieve a suitable slag resistivity. Also the high power fluxes (MW/m² molten
25 bath area) and zinc fuming rates (Zn vapour/h/m²) of a d.c. arc furnace cannot be reached in an a.c. furnace. Careful control of the slag temperature must be

5 maintained in an a.c. furnace to avoid excessive side-wall refractory erosion as a result of the proximity of the electrodes to the furnace lining.

Use has been made of a zinc-splash condenser to condense zinc vapour drawn from a.c. and d.c. furnaces. This approach produces an off-grade zinc, saleable
10 only at a significant discount. Other processes which do not incorporate a condensation stage yield a crude zinc oxide with even greater sale price penalties.

SUMMARY OF THE INVENTION

15

The invention provides a method of extracting at least zinc from zinc-bearing material wherein the zinc-bearing material, in a solid or liquid state, and a reducing agent are fed at a controlled rate to a reaction zone in a d.c. arc furnace including at least molten slag in which at least zinc is volatilized, the volatilized zinc being collected as metallic zinc in a condenser or being burnt and recovered as a crude zinc oxide. The zinc condenser is preferably a lead-splash condenser, but can also be a lead-spray or a surface film-type condenser.

25

The invention may be applied to zinc-bearing secondary materials, or to primary oxidic zinc concentrates.

5 The zinc-bearing material may be raw but preferably is pretreated to the extent that the zinc metal product meets Prime Western grade specifications, or that the crude zinc oxide product meets the criteria for further downstream processing in a zinc recovery plant (eg zinc electrowinning plant or ISF).

10 Appropriate pretreatment depends on the type and chemical composition of the zinc-bearing material and the required quality of the product, and may include dehalogenation, drying, calcining, prereduction and premelting. Pretreatment equipment may include a.c. or d.c. melting furnaces, fluid-bed reactors, rotary kilns, and washing/filtration equipment for aqueous dehalogenation. Additions
15 may be required during the pretreatment step in order to promote the removal of impurities such as S, Cl, F, Na, K, Cd and Cu via an aqueous, a gas or a metal phase. For example additions of sodium carbonate may be necessary for efficient aqueous dehalogenation.

A pretreatment furnace (melting furnace) may be used, for example to hold liquid slag from a lead blast-furnace. This lowers the energy requirement of the d.c. arc furnace (smelting/zinc fuming furnace), and reduces the potential carry-over of feed material to the lead-splash condenser. A pretreatment furnace may also be
25 used to melt and desulphurize zinc leach residues or to melt and dehalogenate EAF dust. The dust may also be subjected to aqueous dehalogenation whereafter the dust is dried at 500°C to 600°C and is then fed, preferably hot, to

5 the d.c. arc furnace. Thermal dehalogenation in a rotary kiln, above 700°C, can also be effected followed by feeding the dust, preferably hot, to the d.c. arc furnace. The molten zinc-bearing material may be transferred continuously, in the liquid state, from the pretreatment furnace to the d.c. arc furnace, via a launder and an underflow weir.

10

Preferably the feed materials comprise lead blast-furnace slag, ISF slag, zinc oxide containing EAF dust, zinc leach residues from an electrolytic zinc plant, primary oxidic zinc concentrates, or combinations of slags, dusts, residues and concentrates.

15

Other elements that are present in the zinc-bearing materials such as iron, lead, copper, silver, molybdenum, cobalt, germanium and gallium may be recovered simultaneously with the zinc, via a metal, matte or speiss phase tapped from the pretreatment furnace or from the d.c. arc furnace (zinc fuming furnace), or via a vapour phase from the pretreatment furnace or from the d.c. arc furnace (zinc fuming furnace).

25

The reducing agent may comprise a carbonaceous material such as metallurgical coke, coal or anthracite, or a metallic reducing agent such as metallurgical grade silicon or ferrosilicon, or combinations of carbonaceous and metallic reducing agents. Low-grade silicon or ferrosilicon fines, often available from ferro-alloy

5 plants, could be used. Optionally a slag fluxing agent such as lime, silica or dolomite may be used.

10 The reductant in the d.c. arc furnace should be present in a quantity which is sufficient to give at least 90% extraction of zinc without excessive reduction of iron oxides to metallic iron, i.e. less than 100kg iron reduced per 1000kg zinc bearing feed material and preferably less than 30kg iron per 1000kg zinc bearing feed material.

15 The carbonaceous reducing agent must have low levels of moisture and volatiles; preferably below 0,2% and 3,0% respectively, and the moisture content of the zinc bearing feed is preferably below 0,1%, for satisfactory zinc condensing efficiencies of at least 70%. Preferably feed materials are supplied hot to the d.c. arc furnace, i.e. at a temperature above 200°C.

25 The d.c. arc furnace (smelting/zinc fuming furnace) contains normally one but could have more graphite electrodes mounted in a suitable geometrical arrangement above the molten bath. Solid or hollow graphite electrodes may be used. The furnace is interfaced, via a relatively short refractory-lined duct, with a zinc recovery unit, preferably a lead-splash condenser or a lead-spray condenser.

5 Solid zinc-bearing material, reducing agents or fluxes may be fed directly to the d.c. arc furnace, via a hollow graphite electrode, or through one or more ports located in a roof of the furnace. Gases such as nitrogen or argon may be supplied to the fuming furnace via the hollow electrode or through the feed ports in the roof.

10

In the case of lead blast-furnace and ISF slag, the molten feed may be transferred from the pretreatment furnace to the d.c. arc furnace at about 1300°C. Spent slag may be tapped continuously or in batches from the d.c. arc furnace. The d.c. arc furnace may be operated so that its tapping temperature is between 1300°C and 15
1600°C, and preferably above 1400°C.

15

It has been established that the furnace should operate at a temperature in excess of 1300°C for satisfactory zinc extraction. On the other hand, above 1500°C there is a diminishing return in terms of zinc extraction, a risk of unacceptable refractory erosion and contamination of the zinc vapour with undesirable species from side reactions, such as the generation of magnesium and manganese vapour and silicon monoxide, at these high temperatures. A consideration of these factors indicates that a desirable operating temperature for the zinc fuming furnace is in the range of 1400°C to 1550°C.

25

5 The slag basicity ratio, i.e. the $(\text{CaO} + \text{MgO}):\text{SiO}_2$ mass ratio, in the fuming furnace may be greater than 0,8 and is preferably more than 1, to achieve more than 90% zinc extraction and to minimize the presence of magnetite, which adversely affects the furnace operation (formation of solid magnetite banks) and the zinc extraction.

10

Preferably the fuming furnace is operated at a power flux of at least $0,3 \text{ MW/m}^2$ or alternatively at a current flux of at least 2 kA/m^2 to achieve zinc fuming rates of over 50 kg Zn/h/m^2 .

15

The furnace and the condenser should be air tight, and operated at slightly positive pressure (10 to 50mm water gauge).

The $\text{CO}:\text{CO}_2$ volume ratio in the fuming furnace should be above 2 and preferably above 10, to prevent reoxidation of zinc vapour in the free board of the furnace, in the duct between the furnace and the condenser, or in the condenser.

25

In the case of EAF dust, the lead, zinc, iron and other oxides in the feed must not react substantially with CO in the free board of the furnace or above the main reaction zone which is the surface interface of the molten slag and the reducing agent. This causes the formation of metallic lead, zinc, iron, etc in the free board, which is partially carried over into the condenser and can result in the production

5 of hard zinc (zinc containing more than 1% iron) instead of Prime Western grade zinc. Furthermore, the reaction of lead, zinc and iron oxides with CO generates CO₂, providing a low CO:CO₂ ratio in the free board, causing the oxidation of zinc vapour.

10 Hard zinc formation and zinc oxidation by CO₂ may to a large extent be prevented by using an optimized addition of a suitably reactive carbonaceous reducing agent which is sufficient to generate a gas above the reaction site with a CO:CO₂ volume ratio greater than 10, and in the case when liquid feed is introduced via an underflow weir, the reaction of lead, zinc and iron oxides with CO in the free
15 board of the furnace is minimized or even eliminated.

For the treatment of EAF dust, feeding of dust pellets or similar agglomerates, feeding through the hollow electrode or injection of feed into the molten slag (for example via a submerged water-cooled lance, a graphite pipe, or a refractory tuyere), or the use of ferrosilicon as reducing agent may further improve the recovery of Prime Western grade zinc from the condenser.

BRIEF DESCRIPTION OF THE DRAWINGS

25 The invention is further described by way of examples with reference to the accompanying drawings in which:

5 Figures 1(a), 1(b) and 1(c) respectively illustrate flow sheets of processes according to the invention for the treatment of lead blast-furnace slags, zinc leach residues, and EAF dusts; and

10 Figure 2 is a schematic diagram of a plant for carrying out the method of the invention for the treatment of lead blast-furnace slags.

DESCRIPTION OF PREFERRED EMBODIMENT

15 Figures 1(a),1(b) and 1(c) are substantially self explanatory and are respectively process flow sheets for the treatment of slags, residues, and dusts, according to the method of the invention.

The process of Figure 1 (a) includes the feeding of lead blast-furnace slags 10, preferably in liquid form, to a holding or premelting furnace 12. In this furnace pretreatment takes place for example in order to desulphurize or to remove copper and cadmium.

25 Continuous transfer, at about 1300°C, of the molten feed from the furnace 12 to a d.c. arc fuming furnace 14 is effected via a launder and underflow weir.

5 A suitable carbonaceous reductant is fed to the smelting furnace and selective high temperature carbothermic reduction of oxidic zinc is carried out in the furnace.

10 The smelting furnace is batch tapped at regular intervals to remove slag, and a limited quantity of metal, mostly iron, is also tapped intermittently from the furnace. This alloy can contain valuable elements such as cobalt and could be processed to recover these elements if economically attractive.

15 Zinc in the slag in the furnace 14 is volatilized and the zinc vapour is condensed in a lead splash condenser 16. Following condensation of the zinc the off-gas is combusted, cooled and passed to atmosphere via a bag-house.

25 In the process shown in Figure 1(b) a substantially similar sequence of steps takes place. This process is intended for the treatment of zinc calcine leach residues, either from first neutral or final acid leach. The leach residues are roasted to remove most of the sulphur and then premelted in a furnace 12 to adjust the composition of the residue, prior to liquid transfer to a fuming furnace 14. Alternatively both roasting and melting are done in the furnace 12. Collection of silver in a bullion phase, from the furnaces 12 and 14, is effected and zinc vapour is passed, as before, to a lead splash condenser 16.

5 The process shown in Figure 1(c) includes aqueous dehalogenation of EAF dust 17, drying of dust in a rotary kiln 19, zinc volatilization in a d.c. arc furnace 14, and condensation of zinc in a lead-splash condenser 16. Alternatively dehalogenation of pelletized dust may be carried out in a rotary kiln operated at 750°C to 1000°C.

10

Figure 2 schematically illustrates a plant 20 according to the invention for the treatment of lead blast-furnace slag.

15

The plant includes first and second d.c. arc furnaces 12 and 14 respectively and a lead-splash condenser 16, numbered with the same reference numerals as the numerals employed in Figure 1 to indicate like components.

The first furnace 12 is a d.c. arc furnace and a launder 22 extends from a tap hole 24 on the furnace to an underflow weir 26 on the second d.c. arc furnace 14.

The furnace 12 has a central hollow graphite electrode 28 and a side port 30 for the feeding of material.

25

The furnace 14 also has a central hollow graphite electrode 32 and a side port 34 for the feeding of material. Tap points 36 and 38 respectively are provided for the tapping of slag and metal from the furnace.

5 Each furnace has a refractory-lined, spray-cooled cylindrical shell, and a water-cooled roof in the shape of a truncated cone. The flat part of the roof contains the feed port 30 or 34, and a central entry port for the graphite electrode 28 or 32. An off-gas port 40 is located at the side of the conical roof of the furnace 12. This extends to a bag-house.

10

In the case of the furnace 14 a gas port extends via a short refractory-lined elbow 42 to the lead-splash condenser 16.

15

The anode in each furnace consists of a number of steel pins vertically positioned in the hearth refractory and attached at their lower ends to a circular steel plate which, via radially extending arms, is linked to the furnace shell and to the anode busbars.

25

The condenser 16 includes a condensing chamber with at least a single impeller 44, although at least up to eight similar impellers may be used, a lead circulation pump or pumps, a cooling launder with two or more immersible banks of cooling pins, a flux bath and a zinc separation bath. The construction of the condenser is substantially conventional in accordance with Imperial Smelting Furnace practise, and for this reason is not further described herein. A lead-spray condenser or a surface film-type condenser may also be used.

5 A gas handling system 46 is provided to treat gas drawn from the condenser. The system includes a refractory-lined combustion chamber 48, water-cooled ducting 50, a radiant gas cooler 52 and a reverse-pulse bag filter 54 the outlet of which is connected to a stack 56.

10 The process variables of major interest for the fuming furnace 14 are the reductant addition and the operating temperature. Carbon additions are calculated to give at least 90% extraction of zinc without excessive reduction of iron. This facilitates the minimization of coke usage, energy consumption and gas handling, since minimal volumes of CO are generated. Carbon levels must
15 however be sufficient to ensure a CO: CO₂ ratio such that the zinc does not re-oxidise before reaching the condenser. Theoretical considerations indicate that about 30kg of coke are needed per 1000kg lead blast-furnace slag and a minimum temperature of about 1350°C is required for 90% zinc extraction. Above 1500°C there is a diminishing return in terms of zinc extraction, a risk of unacceptable refractory erosion and contamination of the fume with undesirable species. Further, the operating temperature must sustain a gas entry temperature to the condenser of at least 1000°C to minimize back-reaction of zinc to zinc oxide. Any iron that is produced is not carbon saturated and cannot be tapped at 1350°C. A consideration of these factors indicates that a desirable operating temperature
25 is in the range of from 1400°C to 1550°C. An optimum region of operation of the

5 fuming furnace is obtained for coke additions between 2% and 5% by mass of the lead blast-furnace slag.

10 In use of the plant 20 granular lead blast furnace slag is supplied from a feed system 58 to the first d.c. arc furnace 12. Hot slag is fed continuously from the premelter, via the transfer launder 22 and underflow weir 26 into the second d.c. arc furnace 14. Metallurgical coke is fed to the fuming furnace 14 through the feed port 34 or via the hollow electrode 32. According to the type of lead-blast furnace slag, and in accordance with the considerations referred to hereinbefore, coke is added at the rate of approximately 30 kg per 1000kg of lead blast-furnace slag.

15 An alternative method of operation is to feed solid lead blast-furnace slag directly to the fuming furnace through the hollow electrode 32 or via the port 34 located in the roof. The premelter furnace is in that case switched off, and the underflow weir is closed with refractories.

25 The zinc and lead oxides in the slag are reduced to their metals and volatilized in the fuming furnace 14. Residual or spent slag is tapped from the fuming furnace at regular intervals through the tap point 36. Metal, primarily iron, is tapped from the furnace 14, as necessary, through the tap point 38.

5 The furnace 14 operates at near atmospheric pressure (less than 200mm water gauge and preferably less than 50mm water gauge but not less than 20mm) and delivers a gas to the elbow 42 and hence to the condenser 44 which consists mainly of zinc vapour, carbon monoxide, carbon dioxide and nitrogen. Zinc vapour is condensed in the condenser and molten zinc is tapped from the
10 condenser, as required.

A cooling launder 60 underlies the condenser 44. Drosses are regularly removed from the cooling launder as they are generated. Gases and dust passing through the condenser are burnt in the combustion chamber 48 and are cleaned in the bag
15 filter 54. Fumes are removed continuously from the bag filter. Gases emitted by the bag filter are monitored for solids content prior to discharge to atmosphere from the stack 56.

To control the smelting operation the theoretical energy requirements in kilowatt
hours for each 1000kg of lead blast-furnace slag to be treated, are calculated for each furnace. Energy losses are measured using cooling flow rates and
temperatures. The operating power levels of the furnaces are determined for selected feed rates. The main control parameters for running the furnaces are the tapping temperatures, which are measured with an optical pyrometer, and the
25 content of zinc in the tapped slags. The designed tapping temperatures of the

5 premelter and fuming furnaces are respectively in the region of 1300°C and 1450°C.

These temperatures are selected to minimize zinc losses in the premelter, to ensure sufficient fluidity, and to achieve a high degree of zinc extraction.

10

The general rule for the operation of the condenser and its cooling system is based on controlling temperature at 500°C ± 50°C. The lead pump speed is increased or decreased when the pump sump temperature is too high or low. If the return launder temperature is too high or low the cooling pins are immersed or withdrawn. Auxiliary fuel burners are used when the launder temperature still remains too low. The temperature of the gas entering the condenser is monitored. Control parameters other than temperature are pressure, rotor speed, and rotor immersion. The pressure in the condenser is kept slightly positive to avoid the ingress of air which could oxidise the zinc vapour and cause accretions.

15

20

It has been found that the plant 20 is capable of producing Prime Western grade zinc which is saleable at attractive commercial rates. The final slag from the furnace 14 consistently meets environmental leach criteria and discard slags are environmentally acceptable for disposal.

25

5 The process can be operated over a wide range of capacities to treat a broad spectrum of oxidic zinc containing materials.

The use of a d.c. arc furnace, when compared to a three-phase a.c. slag resistance furnace, offers reduced electrode consumption, symmetrical heat distribution and a high degree of operational control. Since the graphite electrode is not in contact with the molten charge accurate carbon additions can be made to the melt. The arc furnace generates most of its heat between the electrode tip and the bath and consequently the power input is not restricted by the electrical conductivity of the bath.

EXAMPLES OF THE INVENTION

EXAMPLE 1 - PROCESSING OF LEAD BLAST-FURNACE SLAG

Referring to Figure 1(a), the pilot-plant equipment consisted of two d.c. arc furnaces, a lead-splash condenser, a combustion chamber and a gas-cleaning system. Granular lead blast-furnace slag was premelted in the first d.c. arc furnace (premelter) and hot slag was fed continuously from the premelter, via a transfer launder and an underflow weir, into the second d.c. arc furnace (zinc fuming furnace). The feed rate of lead blast-furnace slag was about 1500kg per hour. Metallurgical coke was also fed to the fuming furnace, at a rate of 30kg per

5 1000kg of lead blast-furnace slag, via a feed port located in the roof. The
 premelter was typically operated at 650kW (200 V, 3,2kA), and the zinc fuming
 furnace was run at about 700kW (175 V, 4 kA). Residual or spent slag was tapped
 from the furnace when about 2500kg of lead blast-furnace slag was fed to the
 premelter. During certain periods of the smelting campaign, the premelter was
 10 switched off, the underflow was closed with refractories, and granular lead blast-
 furnace slag was fed directly to the fuming furnace. In that case the fuming
 furnace was operated at power levels of about 1200kW. In total about 600 metric
 tons of lead blast-furnace slag was processed through the pilot-plant.

15 The lead blast-furnace slag contained 10,9% ZnO, 2,5 % PbO, 23,2% FeO, 26,8%
 SiO₂, 21,6% CaO, 4,8% MgO and 4,0% Al₂O₃. The minor constituents of key
 interest with regard to the production of Prime Western grade zinc were copper
 at 0,4%, arsenic at 0,3%, and cadmium at 70ppm. The metallurgical coke
 contained 76,5% fixed carbon.

20 Typical analyses of products when hot slag transfer was employed are shown in Table 1

Table 1 - Typical analyses of products

| | Non-metallic products, mass% | | | | | | | |
|---------------------|------------------------------|-----|------|------------------|------|-----|--------------------------------|-----|
| | ZnO | PbO | FeO | SiO ₂ | CaO | MgO | Al ₂ O ₃ | CuO |
| Premelter slag | 10,3 | 1,6 | 23,3 | 27,9 | 21,9 | 5,0 | 4,2 | 0,3 |
| Fuming-furnace slag | 1,8 | 0,1 | 21,0 | 32,4 | 26,4 | 7,4 | 5,1 | 0,1 |

| | Metallic products, mass % | | | | | |
|----------------------|---------------------------|-----|------|------|------|------|
| | Zn | Pb | Fe | Cu | As | Cd |
| Premelter metal | 0,3 | 9,5 | 16,4 | 42,1 | 29,2 | - |
| Fuming-furnace metal | 0,1 | 0,6 | 87,1 | 4,5 | 4,6 | - |
| Zinc metal | 98,4 | 1,3 | 0,03 | 0,18 | 0,06 | 0,02 |

5 When comparing the analyses of the premelter slag and the feed lead blast-furnace slag, it can be seen that a great part of the lead and copper were removed from the lead blast-furnace slag during premelting. About 40% of the lead input reported to the fume and metal of the premelter in a ratio of approximately 1 to 3. Also, about 40% of the copper was extracted in the premelter and mainly
10 passed into the premelter metal. Most of the cadmium reported to the fume, and some arsenic was removed as a speiss phase in the premelter. More copper and arsenic were removed via a metal/speiss phase of the fuming furnace.

The levels of ZnO and PbO in the slags tapped from the fuming furnace were
15 below 2% and 0,2% respectively when the furnace was operated such that tapping temperatures of between 1400°C and 1500°C were achieved (temperatures of slags flowing from the furnaces were measured with an optical pyrometer.) Samples of residual slags were submitted for toxicity leaching tests and were found to conform to US EPA regulations for disposal. In most cases, the zinc metal product met Prime Western grade specifications. Sometimes the lead and iron levels were somewhat above the specified maxima. This zinc could have been liquidated to yield Prime Western grade zinc, which is the usual industrial practice. Maximum levels of lead, copper, iron and cadmium in Prime Western grade zinc are 1,4%, 0,20%, 0,05% and 0,20% respectively. Zinc extractions and
25 zinc condensing efficiencies were calculated as follows:

5

$$\% \text{ Zn extraction} = \frac{\text{Zn in feed} - \text{Zn in slag}}{\text{Zn in feed}} \times 100$$

10

$$\% \text{ Zn condensing efficiency} = \frac{\text{Zn in condensed metal}}{\text{Zn in vapour}} \times 100$$

15 Zn in vapour being defined as: Zn in feed - Zn in slag

20 Zinc extractions and zinc condensing efficiencies were calculated this way for selected periods of fairly consistent operation, during which about 120t of lead blast-furnace slag was processed. The zinc extractions varied between 80% and 85%, while the condensing efficiencies were between 70% and 80%.

Zinc fuming rates were calculated for a period during which 60t of cold lead blast-furnace slag was fed at a relatively high feed rate of 2000kg per hour. The amount of zinc fumed was defined as the zinc in the slag fed minus the zinc in the residual slag. Zinc fuming rates of 120kg/h to 180kg/h were achieved, which correspond with zinc volatilization fluxes of 40kg/h/m² to 60 kg/h/m² (based on a molten bath area of 3m²).

30

5 EXAMPLE 2 - PROCESSING OF EAF DUST

Referring to Figure 1(c) about 25t of EAF dust were dehalogenated, dried and fed to the d.c. arc furnace. During aqueous dehalogenation, the chlorine level in the dust was reduced from about 2% to 0,2%. It is known that high levels of halogens, especially chlorine, interfere with the proper operation of the condenser, due to the formation of large quantities of dross. The dehalogenated dust was dried in a rotary kiln at 500°C to 600°C to reduce its water content to below 0,1%. Previous testwork with dehalogenated dust, containing about 0.5% moisture, resulted in the formation of excessive amounts of "toothpaste-like" dross, and consequently no metallic zinc was recovered from the condenser. The dehalogenated and dried EAF dust was fed to the d.c. arc furnace together with metallurgical coke, via the feed port located in the roof of the furnace. The coke addition was 95kg per 1000kg of dust. The furnace was typically operated at 1270kW (200 V, 6,35KA). Dust was fed at a rate of about 1000kg/h and tapping of spent slag was done intermittently, each time when about 3000kg dust was supplied to the furnace. The average slag tapping temperature was 1465°C. The dehalogenated and dried dust contained 24,6% ZnO, 2,3% PbO, 44,7% Fe₂O₃, 4,4% SiO₂, 7,7% CaO, 3,8% MgO, 1,0% Al₂O₃ and 3,3% MnO. The spent slag contained on average 1,6% ZnO and the zinc extraction was about 96%. In total 4097kg zinc was tapped from the condenser. The zinc condensing efficiency was about 80%. Again the slags produced met US EPA regulations for disposal and, in most

5 cases, the zinc metal conformed with Prime Western grade specifications. The average rate of zinc fuming per area of molten bath was 120kg Zn/h/m^2 .

5 CLAIMS

1. A method of extracting at least zinc from zinc-bearing material which includes the steps of feeding the zinc-bearing material and a reducing agent at a controlled rate to a reaction zone in a d.c. arc furnace wherein at least
10 zinc is volatilized, and collecting the volatilized zinc in a suitable form.
2. A method according to claim 1 wherein the zinc-bearing material is in a solid, or liquid, state.
- 15 3. A method according to claim 1 or 2 wherein the volatilized zinc is collected as metallic zinc in a zinc recovery unit.
4. A method according to claim 3 wherein the zinc recovery unit is one of: a lead-splash condenser, a lead-spray condenser, or a surface film-type condenser.
5. A method according to claim 1 or 2 wherein the volatilized zinc is collected by being burnt and then recovered as a crude zinc oxide.

5 6. A method according to claim 3 wherein the zinc-bearing material is pretreated to the extent that the metallic zinc meets Prime Western grade specifications.

10 7. A method according to claim 5 wherein the zinc-bearing material is pretreated to the extent that the crude zinc oxide meets criteria for downstream processing in a zinc recovery plant.

15 8. A method according to claim 6 or 7 wherein the pretreatment includes at least one of the following: dehalogenation; drying; calcining; prereduction; premelting; the removal of impurities via an aqueous, gas or metal phase.

20 9. A method according to any one of claims 1 to 8 wherein the zinc-bearing material includes liquid slag from a lead blast-furnace and which includes the step of using a pre-treatment furnace to hold the liquid slag prior to feeding the liquid slag to the d.c. arc furnace.

25 10. A method according to any one of claims 1 to 8 wherein the zinc-bearing material includes a zinc leach residue and which includes the step of using a pre-treatment furnace to melt and desulphurize the zinc leach residue prior to feeding the molten residue to the d.c. arc furnace.

5 11. A method according to any one of claims 1 to 8 wherein the zinc-bearing material includes EAF dust and which includes the step of dehalogenating the EAF dust prior to feeding the molten dust to the d.c. arc furnace.

10 12. A method according to claim 11 wherein the EAF dust is dehalogenated using one of the following: a pre-treatment furnace; aqueous dehalogenation; or thermal dehalogenation in a rotary kiln.

13. A method according to any one of claims 1 to 8 wherein the
15 zinc-bearing material includes a primary oxidic zinc concentrate which is held in molten form in a pre-treatment furnace.

14. A method according any one of claims 9 to 13 which includes the step of transferring the molten zinc-bearing material continuously, in the
liquid state, from the pre-treatment furnace to the d.c. arc furnace.

15. A method according to claim 14 wherein the molten zinc bearing material is transferred via a launder and an underflow weir to the d.c. arc furnace.

25

5 16. A method according to any one of claims 1 to 5 wherein zinc-bearing material, in a solid state, is fed directly to the d.c. arc furnace via a hollow graphite electrode, or through at least one port in a roof of the furnace.

10 17. A method according to claim 16 wherein the reducing agent and a flux are fed directly to the d.c. arc furnace.

18. A method according to claim 16 or 17 wherein gases such as nitrogen or argon are supplied to the d.c. arc furnace.

15 19. A method according to claim 14 or 15 wherein, when the zinc-bearing material is liquid slag from a lead blast-furnace, the molten zinc-bearing material is transferred to the d.c. arc furnace at about 1300°C.

20. A method according to claim 14, 15 or 19 wherein the d.c. arc furnace is operated so that its tapping temperature is between 1300°C and 1600°C.

25 21. A method according to any one of claims 14, 15, 19 and 20 wherein spent slag is tapped continuously, or in batches, from the d.c. arc furnace.

5 22. A method according to any one of claims 1 to 8 wherein the zinc-bearing material includes at least one of the following: lead blast-furnace slag; ISF slag; zinc oxide containing EAF dust; zinc leach residues from an electrolytic zinc plant; primary oxidic zinc concentrate; zinc ore.

10 23. A method according to claim 22 which includes the steps of recovering at least one of iron, lead, copper, silver, molybdenum, cobalt, germanium and gallium simultaneously with the zinc via a metal, matte or speiss phase tapped from a pre-treatment furnace or from the d.c. arc furnace, or via a vapour phase from a pre-treatment furnace or from the d.c. arc furnace.

15 24. A method according to any one of claims 1 to 23 wherein arsenic is removed via a speiss phase from the zinc-bearing material in a pre-treatment furnace or in the d.c. arc furnace.

25 25. A method according to any one of claims 1 to 24 wherein the reducing agent includes a carbonaceous material.

26. A method according to claim 25 wherein the carbonaceous material is metallurgical coke, coal or anthracite.

27. A method according to any one of claims 1 to 26 wherein the

5 ... reducing agent includes a metallic reducing agent.

28. A method according to claim 27 wherein the metallic reducing agent is silicon or ferrosilicon.

10 29. A method according to any one of claims 1 to 28 wherein the reducing agent is present in a quantity sufficient to give at least 90% extraction of zinc without excessive reduction of iron oxides to metallic iron.

15 30. A method according to any one of claims 1 to 29 wherein the d.c. arc furnace is operated at a temperature in excess of 1300°C.

31. A method according to claim 30 wherein the d.c. arc furnace is operated at a temperature in the range of from 1400°C to 1550°C.

32. A method according to any one of claims 1 to 31 wherein the slag basicity ratio in the d.c. arc furnace is adjusted to be greater than 0,8.

33. A method according to claim 32 wherein the said ratio in the d.c. arc furnace is greater than 1.

25

5 34. A method according to any one of claims 1 to 33 wherein the d.c. arc furnace is operated at a power flux of at least $0,3 \text{ MW/m}^2$, or at a current flux of at least 2 kA/m^2 .

10 35. A method according to any one of claims 1 to 34 wherein the d.c. arc furnace is operated at a slightly positive pressure.

15 36. A method according to any one of claims 1 to 35 wherein the CO:CO₂ volume ratio in the d.c. arc furnace is greater than 2.

37. A method according to claim 36 wherein the said ratio is greater than 10.

38. A method of processing lead blast-furnace slag substantially as hereinbefore described in Example 1.

39. A method of processing EAF dust substantially as hereinbefore described in Example 2.

25 40. A method of processing lead blast-furnace slag substantially as hereinbefore described with reference to Figure 2.

5 DATED THIS 15th DAY OF JUNE 1996

10 McCALLUM, RADEMEYER & FREIMOND
Patent Agents for the Applicant

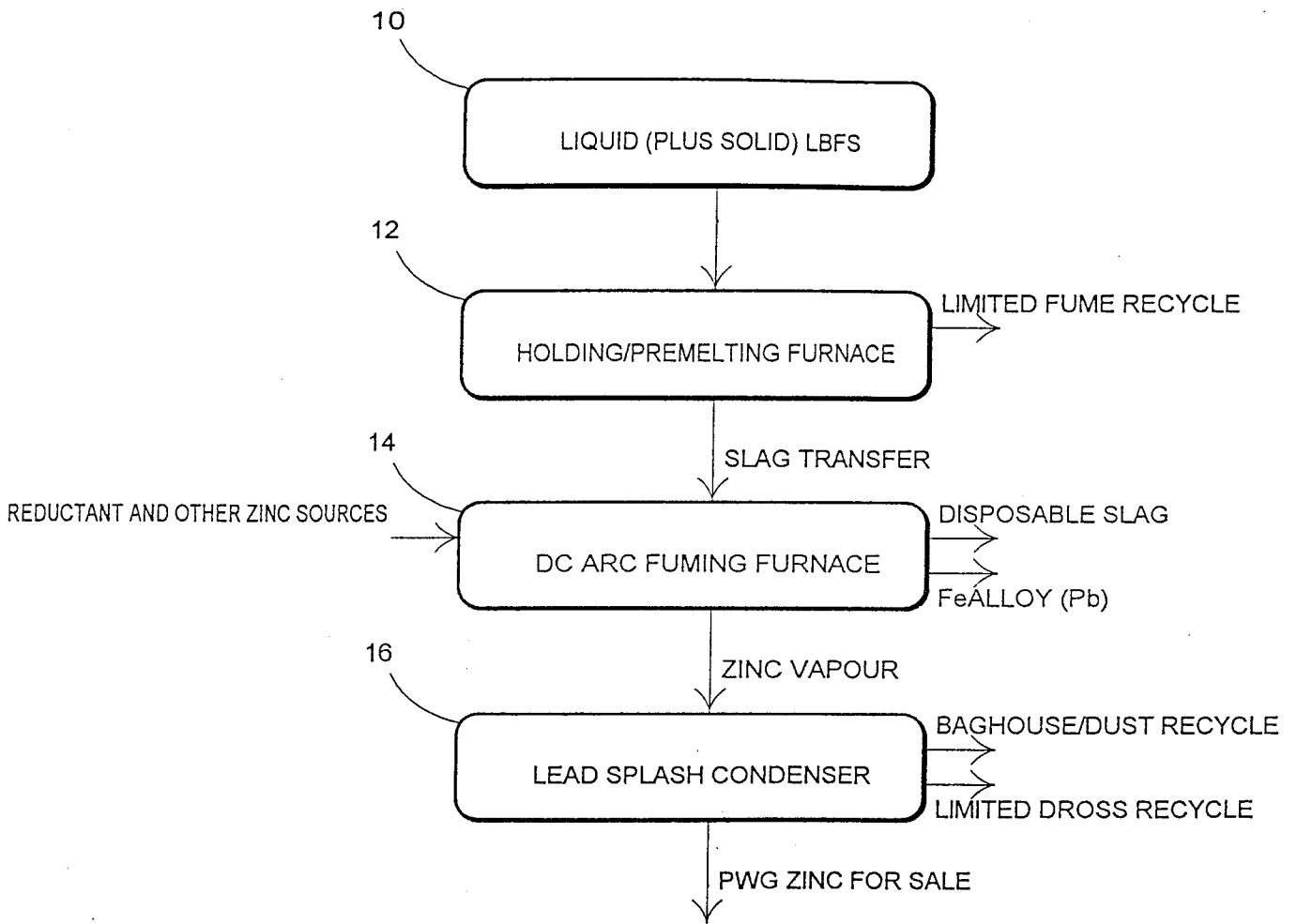

FIG 1(a)

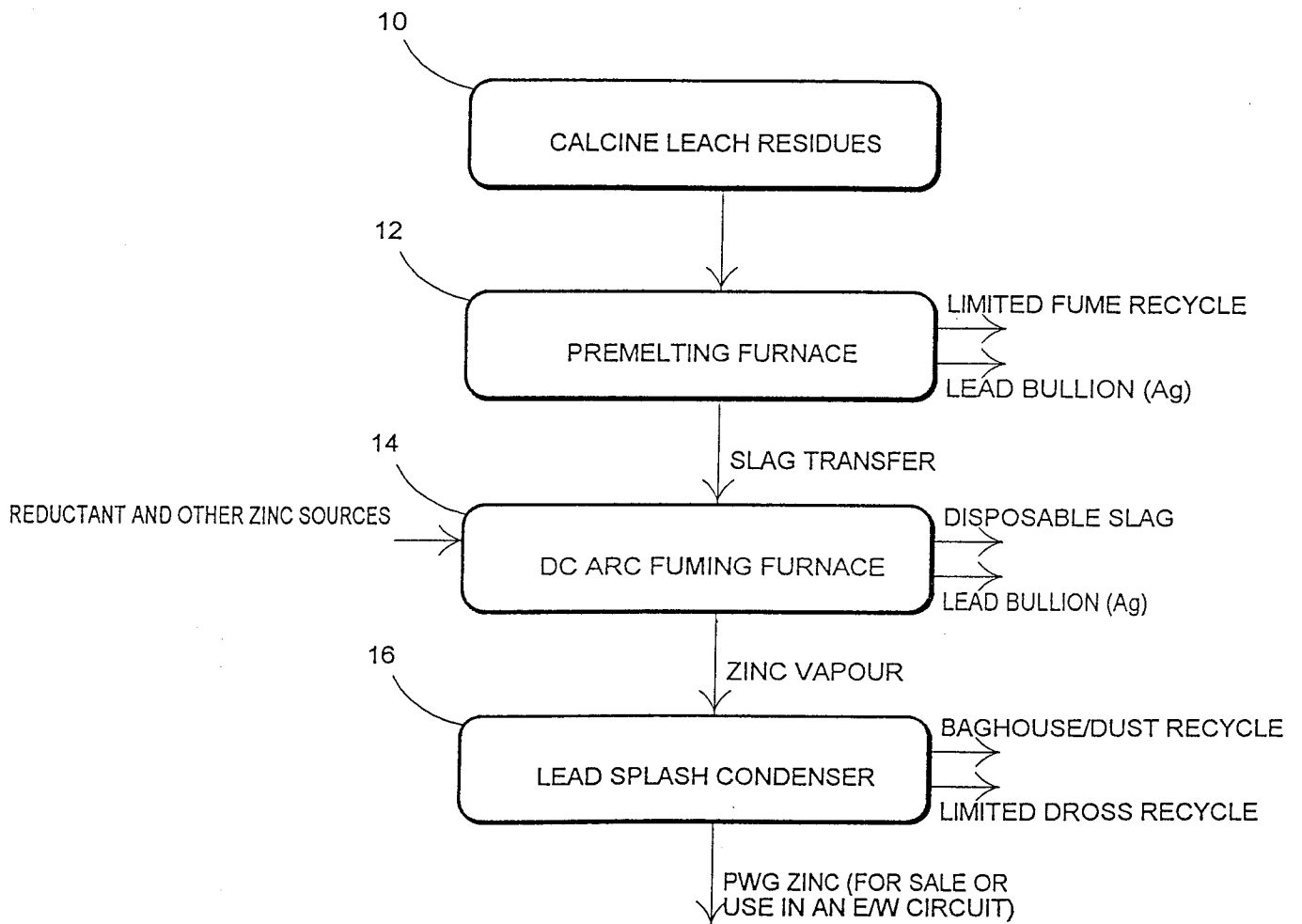

FIG 1(b)

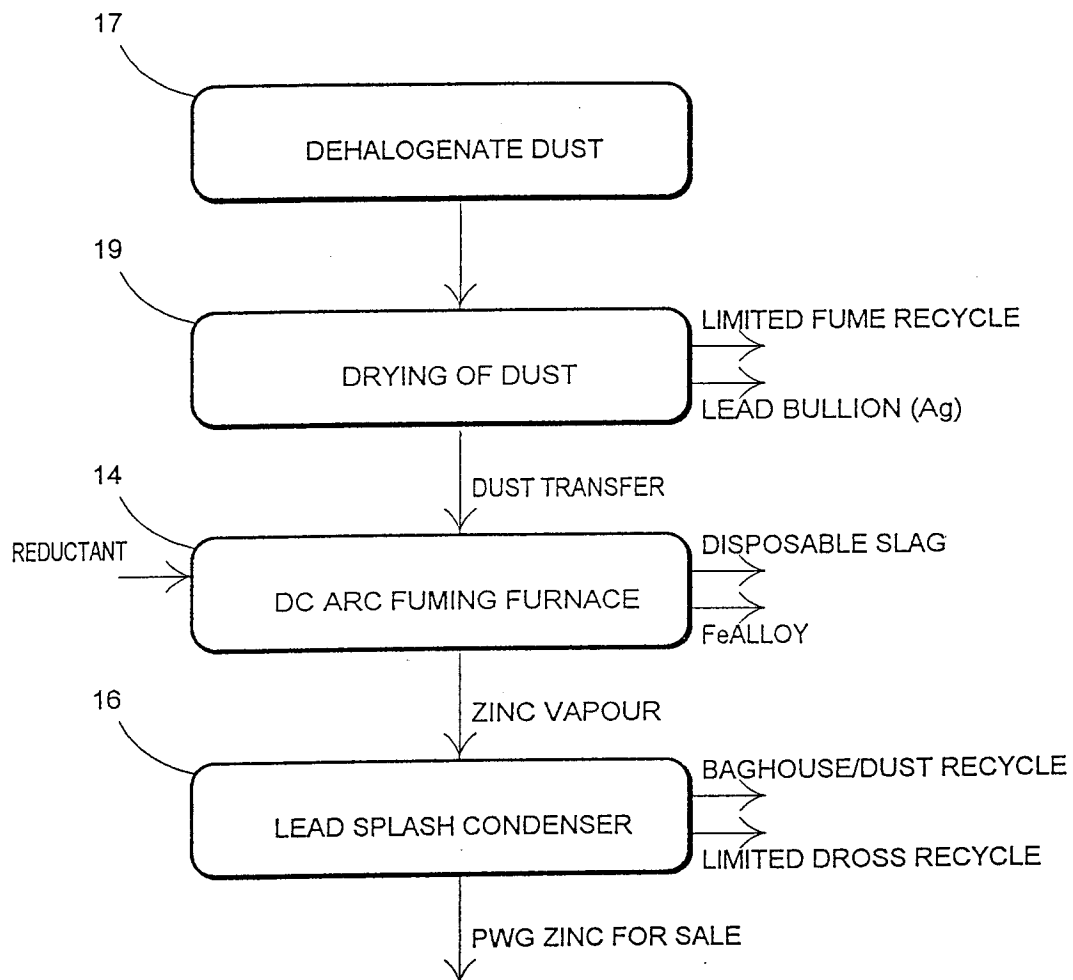
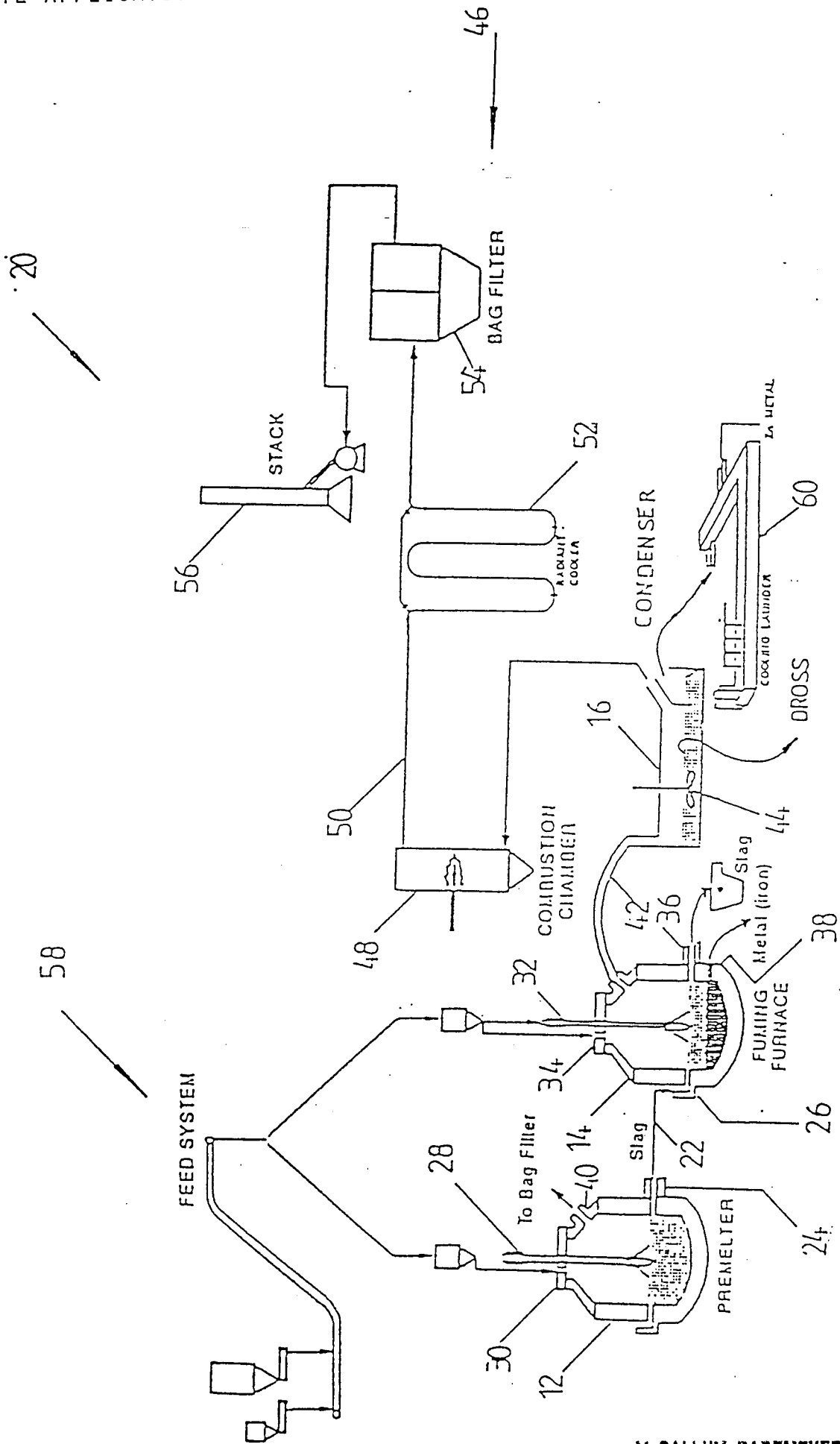

FIG 1(c)



-FIG 2-