

Fe Ni Patent

John & Kernick

Patent Attorneys and Trade Mark Agents
Attorneys, Notaries and Conveyancers

Mintek
Private Bag X3015
Randburg
2125

Att: Dr S A Allison

18th August, 1994

FILE	17/8/155
MINTEK	
ONTVANG - RECEIVED	
RE-STRASIE-REGISTRY	
AANDAG - ATTENTION	
24-08-1994	
COMPLETED	PEND.
<i>Dr. Allison</i>	<i>[initials]</i>
NOTES	

Postal Address
P.O. Box 727
Johannesburg
Republic of South Africa
2000

Office Address
Kernick House
10 Bath Avenue
Rosebank
Johannesburg

Also at Pretoria
and practicing in Botswana,
Lesotho, Swaziland, Venda,
Bophuthatswana, Transkei,
and Namibia

Telephone
(011) 788-1160
Int. +27/11 788-1160

Facsimile
(011) 788-3307
Int. +27/11 788-3307

Telex
4-26051 SA
alternative 3-21325 SA

Our Reference: P 12027 ZA /MVS

Your Reference: 17/0/155

SOUTH AFRICAN PATENT APPLICATION NO. 94/6071
entitled THE PRODUCTION OF FERRONICKEL FROM NICKEL
CONTAINING LATERITE.

(Based on your earlier S.A. Provisional Application No. 93/3055)

Dear Sirs

We have pleasure in advising that the above complete application was filed at the Patent Office on the 12th August, 1994 and was numbered as shown above. Any articles manufactured and which embody the invention, and any literature relating to the invention, should be marked "Pat. Appl. 94/6071".

This application will automatically proceed to publication and grant in due course and we shall keep you fully informed of further progress made in this regard. Also, we refer you to the enclosed information sheet which you should read carefully.

We enclose a copy of the complete specification as filed at the Patent Office together with our Invoice in respect of our services and disbursements.

Yours faithfully

[Signature]
JOHN & KERNICK

SA Patent No. 94/6071

ABSTRACT

A process for the production of ferronickel from nickel containing laterite is provided wherein the laterite includes at least a proportion of relatively fine material of size less than 10mm. The feed material may also be composed substantially or entirely of laterite fines or dust and also partially treated dust arising from conventional treatment routes, and may be pre-reduced, optionally after drying. The laterite is fed to the central region of the molten bath of a circular furnace in which at least one electrode in the roof acts as cathode, and the molten bath itself acts as anode. The process can be used to economically treat fine laterite ore previously discarded and stockpiled and even formerly non-viable deposits of laterite, and fines or dust arising from conventional treatment plants.

- 2 -

THE PRODUCTION OF FERRONICKEL FROM
NICKEL CONTAINING LATERITE

FIELD OF THE INVENTION

THIS INVENTION relates to the production of ferronickel from nickel containing laterite and, more particularly, is concerned with a process whereby it may be possible to utilise laterite fines and dust, large quantities of which have been stockpiled over the years as feedstock. Possibly more importantly, the invention relates to

/a process

a process in which production costs can be decreased with the added consequence that processing of previously uneconomical ore bodies may become viable.

BACKGROUND OF THE INVENTION

The 'oxidised' ores of nickel constitute by far the world's largest known reserves of this metal. The term 'oxidised' is meant to include not only the true laterites, in which the nickel oxide is intimately associated with limonitic iron oxide, but also the silicate ores which often contain the mineral garnierite. These oxidised ores are found in regions of the world where tropical weathering occurs, or where at least sub-tropical conditions have prevailed in geological times.

Mined laterite ore, being of a porous nature, can hold a large content of free moisture, commonly 25 to 30 percent H₂O, although it can contain as much as 40 percent or more. Moreover, combined water, which is not driven off until a temperature of 700 to 800°C is reached, can amount to up to 15 per

/cent based

cent based on the dry ore weight. This indicates the necessity of drying and preferably calcining the ore before smelting.

X.

Because of the friable nature of laterites, run-of-mine ore is normally screened as the first step of a ferronickel operation. In the screening operation alone, up to 50 percent undersize particles may be screened out because of the difficulties in effecting a physical separation of wet laterite at a lower size than 6 to 8mm. This material would then require some form of agglomeration (e.g. sintering or pelletising) before further processing. It is conceivable that the material could be dried before screening to say 1 or 2mm prior to calcining.

X.

However, fines and dust are generated in the drying process and dust generation in the calcining step is also increased. In the drying/calcining step large amounts of fines/dust are generated which are unsuitable for smelting in a conventional electric arc furnace. Once again, these fines need to be extracted and, if they are to be utilised, need to

/be agglomerated

X. be agglomerated at considerable expense. If dusts are captured in a wet scrubber and returned with the fresh ore to the drier, the dust recycle load in the circuit would increase with a consequent increase in the energy requirements for drying.

X. Added to this problem is one of the chemical composition of the laterite. The composition usually varies considerably and often one body of ore will have an undesirably high Si:Mg ratio. A normal electric furnace is difficult to operate with a Si:Mg ratio of greater than 2.0. Also, some ore bodies have an iron content of greater than 20% by weight, and such high iron contents are unworkable in a normal furnace as it tends to cause slag foaming.

The solution employed at present to the problems associated with the chemical composition of the ore is to blend different ores to provide an acceptable feedstock for a normal furnace. This is, to say the least, inconvenient and costly.

/It is

It is the object of this invention to provide a process for the thermal reduction and smelting of nickel-containing laterites in which the disadvantages outlined above are, at least to a significant extent, obviated.

SUMMARY OF THE INVENTION

In accordance with this invention there is provided a process for the reduction and smelting of nickel containing laterite ores, or dust, to yield an unrefined ferronickel product and wherein at least 20% by weight of the laterite has a size of minus 10mm, the process comprising feeding feed material either in the form of pre-reduced nickel containing laterite or as nickel containing laterite simultaneously with a carbonaceous reductant, to the central region of the molten bath of a cylindrical furnace of d.c. arc furnace type having one or more electrodes situated in the roof acting as cathode and the molten bath acting as an anode, and wherein the feeding of the furnace is on a continuous basis; and periodically or continuously

/withdrawing nickel

withdrawing nickel depleted slag and ferronickel from the furnace.

Further features of the invention provide for a frozen lining to be maintained between the molten bath and the refractory lining by controlling the power and feedrates supplied to the furnace and optionally water-cooling the furnace sidewalls; for the electrodes situated in the roof of the furnace to be graphite electrodes; for there to be only one such electrode which is located centrally; for the one or more electrodes to be hollow in which case reactants are preferably introduced into the furnace by way of the bore of such hollow electrode or electrodes; for air to be substantially excluded from the interior of the furnace in which case enhancement of the exclusion of air may be achieved by operating the furnace at a slightly positive pressure; and for the furnace to be a plasma d.c. arc furnace.

Still further features of the invention provide for the recovery of energy by using the thermal calorific value of the off-gases from the furnace,

/optionally after

optionally after cleaning, to dry, calcine, preheat or pre-reduce the feed material; for the feed material to be composed of at least 50% having a particle size of minus 10mm; and for the feed material to include recycled slag produced in a downstream converter for purifying the unrefined ferronickel product produced in the process of the invention.

The invention still further provides, as one alternative thereof, for the laterite to be pre-reduced to meet a required final ferronickel specification, prior to introduction into the furnace. In such a case the laterite ore is preferably dried first followed by dry milling; and calcining at about 700 to 800°C in a fluidised calciner. The calcined laterite is then pre-reduced in a fluidised reduction reactor at about 800-850°C prior to feeding to the furnace bath as defined above.

This variant of the process of the invention has even greater advantages in cases where the $\text{SiO}_2:\text{MgO}$ ratio is what would normally be regarded as

/excessively high.

excessively high. No SiO_2 would be reduced in the pre-reduction step and accordingly does not appear in the molten metal produced in the furnace. Also, by selective pre-reduction of NiO and Fe_2O_3 in the pre-reduction step the ratio of Ni to Fe in the metal can be effectively controlled. A smaller furnace, by comparison, is thus foreseen in such a variant of the invention since melting requires less energy than smelting, especially if SiO_2 were also to be reduced to some extent in the smelting process.

Clearly, in all cases the feed rate of materials and the energy input into the furnace are adjusted to achieve and maintain desired bath and tapping temperatures of both slag and molten metal as well as, where required, the protective freeze lining to protect the furnace lining against excessive wear. Such a protective lining is regarded as essential to the protection of the furnace in all cases where the SiO_2 to MgO ratio is greater than 1,5.

Preferably, the carbonaceous reductant is employed in such quantities that the nickel content of the

/slag is

slag is below 0,1 percent and to ensure that oxygen in the off-gases is substantially in the form of carbon monoxide and the temperature of the furnace is controlled to between 1500 and 1600°C.

Probably the most important feature of the invention is the fact that a wide range of laterite ores can be processed. This is due to the fact that in the d.c. transferred arc plasma furnace the electrical resistance is mainly in the arc and to a lesser extent in the open-bath slag. In particular the advantages are illustrated in the examples below. Example 1 demonstrates the smelting of laterite ore fines and dusts (even 100% < 100µm); the smelting of partially calcined laterite ores; and, the smelting of nickel-containing slags; which can be recycled from a subsequent converter or refining step.

In example 2, there is illustrated the smelting of laterite types over a wide range of SiO₂/MgO ratios, ie. 1,2 to 3,0; and, the smelting of laterite types over a wide range of Fe contents ie. 14 to 20%. Additional advantages with respect to

/the open

the open bath smelting technology include i) the control of the bath temperature to control slag foaming with high iron containing slags, and ii) effective control of the reductant requirement since there is no contact between the graphite electrode and the melt.

Although, in the examples mentioned above, feed materials were not pre-reduced, the above features would make it possible to conduct a final reductant trimming addition to the furnace if pre-reduced materials were to be smelted. Since the d.c. plasma furnace can smelt fine materials, a fluid bed reactor can be linked up with the plasma furnace as in the case of example 2. Although in the example feed materials were only preheated with liquid petroleum gas, one could conduct pre-reduction using a carbonaceous reductant (solid or gaseous) or alternatively, and preferably, furnace off gases to effect preheating/pre-reduction. Preferably, the carbonaceous reductant is employed in such quantities that the nickel content of the slag is below 0,1%.

/In order

In order that the invention may be more fully understood, examples thereof will now be described in greater detail. In the description of example 2 reference will be made to the accompanying drawings.

BRIEF DESCRIPTION OF THE DRAWINGS

In the drawings:-

FIG. 1 is a schematic sectional elevation of a furnace; and,

FIG. 2 is a similar view of a fluidised bed.

DETAILED DESCRIPTION OF EXAMPLES OF THE INVENTION

EXAMPLE 1

In this example tests were conducted in a 100 kVA furnace manufactured by the applicant. The furnace was of a known d.c. plasma-arc furnace type employing a single graphite electrode located centrally above the furnace bath. A direct current power supply was employed in which the molten bath

/formed, in

formed, in use, the anode, while the graphite electrode formed the cathode.

The furnace which had an outside diameter of 600mm and a refractory lining thickness of 114mm, was lined with a refractory material wherein the MgO content was approximately 96 percent. The hearth was lined with a chrome-magnesite rammable material to a thickness of 310mm and a number of mild steel rods were used to make the d.c. (anode) electrical connection from the molten bath through the hearth refractory to the anode cable. The molten bath in the furnace was heated to the desired operating temperature, with an initial metal charge.

The feed materials consisted of calcined laterite dust ($<100\mu\text{m}$) from an industrial rotary kiln calciner (Tests A and C), -6mm laterite ore fines calcined at 250°C (Tests B and D) and -4mm charcoal (all four tests), having the compositions detailed in Table 1. The feed materials were passed through a feed port in the furnace roof into the reaction zone and the liquid products were tapped intermittently from the furnace. For Test D a

/somewhat smaller

somewhat smaller furnace shell, with water-cooling of the sidewalls, was used on the 100 kVA power supply, to increase the number of samples obtainable at the scale of operation.

Results of the smelting tests showing metal, and slag compositions are given in Table 2.

TABLE 1

CHEMICAL ANALYSIS OF THE FEED MATERIALS (MASS %)

Component	Laterite fines (calcined @ 250° C)	Laterite dust	Charcoal
NiO	1,96	2,45	-
Fe ₂ O ₃	39,1	36,8	-
MgO	12,2	17,5	0,2
SiO ₂	30,7	34,4	4,3
Al ₂ O ₃	5,60	3,83	0,8
CaO	0,50	0,25	0,4
MnO	0,69	0,58	-
Cr ₂ O ₃	2,51	1,15	-
Fixed Carbon	-	0,79	64,0
Moisture	9,17	2,0	5,6
Volatiles	-	-	23,3

TABLE 2A

SMELTING OF FERRONICKEL FROM
LATERITE FINES AND DUST

Test Series	Batch	Mild Steel %	Laterite Fines %	Dust %	Char-coal (kg)	Slag (kg)	Ferro-nickel (kg)	Slag (kg)
5 A	Start	1.50						
	1			5.90	0.51			
	2			7.00	0.52			4.30
	3			7.00	0.44		0.22	9.50
	4			7.00	0.44		0.12	8.30
	5			7.00	0.37		1.86	16.60
10 B	1		7.00		0.60			
	2		7.00		0.52			
	3		7.00		0.44			5.10
	4		7.00		0.44			4.20
	5		10.00		0.63			8.60
	6		7.00		0.37			27.50
15 C	Start	6.00	1.00					
	1 3			10.00 10.00	0.63 0.63		0.08	21.40
20 Furnace Contents							7.00	8.60
25 D	Start	4.5 + 1.5Ni						
	1				0.11	4.90	0.20	2.30
	2				0.11	4.00	0.78	2.50
	3				0.12	5.00		2.10
	4		5.00		0.70			3.30
	5		5.00		0.70		0.27	2.60
	6		5.00		0.84		8.00	4.90

TABLE 2B
METAL ANALYSES (MASS %)

Test	Tap #	Ni	Fe	Si	Cr	P	S	C
A	3	0.06	99.10	0.15	0.08			
	4	0.21	99.60	0.11	0.05			
	5	14.70	84.30	0.05	0.06	0.02	0.10	0.05
C	3	7.82	90.50	0.18	0.04			0.10
Digout		8.43	90.90	0.02	0.05		0.22	0.02
D	5	23.30	72.80	0.75	0.20			
	6	16.60	83.10	0.05	0.40			

TABLE 2C
SLAG ANALYSES (MASS %)

Test	Tap #	NiO	FeO	SiO2	Cr2O3	MgO	CaO	MnO	Al2O3
A	2	0.11	43.10	20.30	5.45	27.60	0.21	0.52	4.67
	3	0.06	42.08	21.40	4.98	27.00	0.02	0.53	3.99
	4	0.04	41.90	23.20	4.88	27.00	0.02	0.53	4.05
	5	0.19	40.20	17.70	6.23	30.90	0.02	0.47	4.72
B	3	1.37	36.70	25.40	4.74	26.50	0.40	0.57	5.89
	4	1.35	37.90	24.90	4.69	24.80	0.46	0.60	5.80
	5	1.04	38.50	26.80	3.70	24.30	0.49	0.63	6.14
	6	1.18	37.30	28.00	4.12	25.30	0.40	0.59	5.55
C	3	0.15	29.90	29.30	4.09	28.30	0.39	0.65	4.73
D	1	0.24	32.30	25.00	3.73	29.30	0.55	0.96	7.10
	2	0.88	33.10	24.80	4.21	29.80	0.55	0.72	6.43
	3	0.01	33.40	26.50	3.13	28.30	0.64	0.74	6.93
	4	0.03	23.00	34.10	3.83	28.40	0.70	1.12	8.51
	5	0.71	26.00	34.30	2.85	27.40	0.76	1.00	8.16
	6	0.19	16.50	36.70	3.55	32.90	0.70	0.95	8.83

From the above it will be seen that even extremely fine (<100 μm) nickel-containing laterite can be utilised effectively in a d.c. plasma-arc furnace. Nickel levels could be stripped from the produced slag to less than 0,1%, when laterite fines and dusts were smelted as well as when nickel-containing slags were processed.

EXAMPLE 2

A 200 kVA d.c. transferred arc plasma facility was used in this example. The furnace, as shown in Fig. 1 comprised a water-cooled refractory lined shell 1 and conical roof 2, a graphite electrode and an anode configuration comprising various pins 3 protruding the hearth refractory 4. Sidewall and hearth refractories were of a high quality magnesite type. The internal diameter of the furnace was 760mm. There were two tapholes ie. a bottom taphole 5 for metal product and a top taphole 6 for slag drainage. The two taphole system ensured efficient metal/slag separation. Four ports 7 were located in the furnace roof, namely an electrode entry port 7a a view port (not shown), a gas extraction port 7b and a feed port

7c. Not shown are ancillaries namely the power supply, control system, gas cleaning system and water circuits. Fig. 2 shows the LPG heated fluid bed reactor which had been used to preheat the calcined laterite feed to about 600°C prior to smelting the preheated materials in a few cases in test 2 (FBR). The FBR had an inlet 8 for laterite, and an outlet 9 opposite the inlet, a lower inlet 10 for fluidising air and liquid petroleum gas (LPG) and an off gas outlet 11. A change in diameter of the interior of the reactor and located between the material inlet 8 and outlet 9, forms the region in which the solids become less fluidised, to limit fines carry over to the off gas 11.

The laterites, when dried, had a loss on ignition (LOI) value of 11,5%. Prior to the smelting testwork, the laterite ores were calcined to a residual LOI of 6,5%.

The smelting campaign was conducted on a continuous basis over a period of 7 days, and about 7,2 tons total material was smelted. Table 3 summarises on

/a tap-to-tap

a tap-to-tap basis, the Ni content of the metal and slag, as well as the SiO_2/MgO ratios and iron contents in the laterite and the slag.

For the purposes of all tests that were conducted by feeding the laterite directly to the furnace, the laterite was screened to a particle size of minus 8mm. In the case of heating at 600C (in a fluidised bed reactor (see tests indicated by FBR in Table 3)) prior to feeding to the furnace the feed material was screened to minus 2mm.

TABLE 3

Test No	Tap No	Laterite Batch kg	Coal Batch kg	Fixed carbon *	% Ni in Metal	% NiO in Slag	Desgn SiO ₂ /MgO Ratio	Actual SiO ₂ /MgO Ratio	% Fe in Laterite	% Fe in Slag
5	Warm up	50								
1	1	96.2	2.10	0.96	4.34	0.04	1.51	1.56	17.25	78.60
	2	62.6	10.00	6.22	6.10	0.04	1.51	1.44	17.25	21.80
	3	100	10.00	4.10	5.69	0.13	1.51	1.44	17.25	11.90
	4	100	10.00	4.10		0.52	1.51	1.41	18.37	16.90
10	5	26.2	10.00	12.47		0.17	1.51	1.31	18.37	16.10
	6	100	10.00	4.10	7.82	0.04	1.51	1.47	17.80	7.50
	7	100	10.00	4.10	9.07	0.09	1.51	1.45	17.31	10.20
	8	100	10.00	4.10	1.78	0.09	1.51	1.51	17.56	10.00
	9	100	7.00	2.95	12.50	0.22	1.51	1.51	16.91	10.20
15	10	100	5.00	2.15		0.86	1.51	1.52	16.82	20.00
	11	100	5.00	2.15		0.80	1.51	1.46	16.77	28.90
	12	100	7.00	2.95		0.26	1.51	1.36	16.85	29.80
	13	100	7.00	2.95	3.58	0.11	1.51	1.39	17.15	30.80
	14	100	8.50	3.54	1.23	0.16	1.51	1.52	17.56	21.30
20	15	100	8.50	3.54	0.90	0.07	1.51	1.66	17.56	17.80
	16	100	7.00	2.95		0.04	1.51	1.32	17.74	17.10
	17	100	7.50	3.15	19.90	0.04	1.51	1.41	15.95	15.40
	18	100	7.50	3.15		0.06	1.51	1.38	16.57	26.40
25	2	100	7.50	3.15		1.21 →		14.47 →	18.90 →	
	20	50	3.75	3.15			1.21		14.61	
	21	50	3.75	3.15	20.70	0.04	1.21	1.13	15.03	
	22	200	15.00	3.15			1.21		15.03	16.50
	23	100	7.50	3.15	17.90	0.04	1.21	1.25	15.83	
30	24	100	7.50	3.15			1.21		14.94	13.50
	25	150	11.25	3.15		0.07	1.21	1.20	14.94	
	26	50	3.75	3.15	17.80	0.04	1.21	1.20	14.92	11.30
	27	100	7.30	3.07			1.21		14.96	10.90
	28	150	10.95	3.07		0.04	1.21	1.21	15.00	
	29	50	3.65	3.07	16.40	0.04	1.21	1.21	14.65	15.30
35	2	100	7.30	3.07			1.21		14.72	13.50
	31	150	10.95	3.07		0.04	1.21	1.14	14.49	
	32	50	3.65	3.07	16.30	0.07	1.21	1.19	14.69	9.80
	33	100	7.00	2.95			1.21		14.87	12.90
	34	150	10.50	2.95		0.07	1.21	1.20	14.77	
40	2	50	3.50	2.95			1.21		14.53	13.10
	36	50	3.50	2.95	15.70	0.12	1.21	1.14	14.63	

kg Carbon/ 100 kg feed material

TABLE 3 (Cont)

Test No	Tap No	Laterite Batch kg	Coal Batch kg	Fixed carbon *	% Ni in Metal	% NiO in Slag	Desgn SiO2/ MgO Ratio	Actual SiO2/ MgO Ratio	% Fe in Laterite	% Fe in Slag	
5	FBR	37	250	16.25	2.76	16.80	0.08	1.21	1.36	14.61	13.5
	FBR	38	250	16.25	2.76	16.40	0.51	1.21	1.24	15.03	17.9
	FBR	39	250	16.25	2.76	18.10	0.36	1.21	1.32	14.98	17.80
	FBR	40	169.3	9.29	2.35	18.90	0.65	1.21	1.25	14.99	22.30
10	3	41	100	6.50	2.76			1.50	19.05	21.60	
	3	42	150	9.75	2.76		0.11	1.50	1.29	19.60	
	3	43	50	3.25	2.76	16.10	0.11	1.50	1.31	19.54	14.90
	3	44	100	6.50	2.76	22.60	0.51	1.50	1.40	19.56	16.40
	3	45	150	9.00	2.56			1.50		19.49	24.20
	3	46	100	6.00	2.56		0.10	1.50	1.52	19.22	
15	3	47	50	3.00	2.56	19.90	0.11	1.50	1.51	19.71	24.50
	3	48	100	6.00	2.56			1.50		19.12	26.80
	3	49	150	9.00	2.56		0.09	1.50	1.41	19.07	
	3	50	50	3.00	2.56	21.30	0.16	1.50	1.44	19.31	26.00
	3	51	100	6.00	2.56			1.50		20.62	26.60
20	3	52	150	9.00	2.56		0.15	1.50	1.40	18.97	
	3	53	50	3.00	2.56	23.30	0.27	1.50	1.43	19.01	27.00
25	4	54	100	6.00	2.56			1.71		14.80	27.70
	4	55	150	9.00	2.56		0.06	1.71	1.52	14.77	
	4	56	50	3.00	2.56	22.10	0.18	1.71	1.56	14.84	19.90
	4	57	100	6.00	2.56			1.71		14.93	19.20
	4	58	150	9.00	2.56		0.10	1.71	1.71	14.82	
	4	59	50	3.00	2.56	23.20	0.07	1.71	1.69	15.96	20.50
	4	60	100	6.00	2.56			1.71		15.29	20.90
	4	61	150	9.00	2.56		0.06	1.71	1.54	15.00	
	4	62	50	3.00	2.56	21.50	0.25	1.71	1.59	15.29	16.10
30	5	63	100	6.00	2.56			3.00		19.83	17.10
	5	64	150	9.00	2.56		0.09	3.00	2.18	19.61	
	5	65	50	3.00	2.56	21.70	0.10	3.00	2.14	20.69	20.20
	5	66	100	6.00	2.56			3.00		20.69	18.20
	5	67	150	9.00	2.56			3.00		20.69	
35	5	68	50	3.00	2.56	20.20	0.43	3.00	2.37	20.69	

* kg Carbon/ 100 kg feed material

It is envisaged that an extremely effective and economic process is provided by this invention in that in addition to the smelting of a wider range of conventional laterite blends, laterite ores (crushed or uncrushed, dried or undried, calcined or uncalcined) and dusts can also be utilised directly in the production of ferronickel.

It is also envisaged that the process of this invention can be combined with various other processes or operations to form a variety of combined processes. These include processes in which a fraction or all of the reductant is added in a reactor and any remainder is added to the furnace; processes in which a conventional process is applied to coarse laterites and the process of the invention is applied in parallel, to the fines which may even be constituted by a waste stream (eg. kiln dust); and processes in which the invention is included in to a conventional arrangement having conventional upstream processing steps, as well as downstream refining steps ((drying, calcining/prereduction)) to lower P, S, C and Si, and Cr contents of the ferronickel produced.

x

/

WHAT IS CLAIMED IS:-

1. A process for the reduction and smelting of nickel containing laterite ores, or dust to yield an unrefined ferronickel product and wherein at least 20% by weight of the laterite has a size of minus 10mm, the process comprising feeding feed material either in the form of pre-reduced nickel containing laterite or as nickel containing laterite simultaneously with a carbonaceous reductant, to the central region of the molten bath of a cylindrical furnace of d.c. arc furnace type having one or more electrodes situated in the roof acting as cathode and the molten bath acting as an anode, and wherein the feeding of the furnace is on a continuous basis; and periodically or continuously withdrawing nickel depleted slag and ferronickel from the furnace.

2. A process as claimed in claim 1 in which a frozen lining is maintained between the molten

/bath and

bath and the refractory lining by controlling the power and feedrate supplied to the furnace, and optionally by water cooling the furnace sidewalls.

3. A process as claimed in either of claims 1 or 2 in which the feed material is composed of at least 50% by mass of sizes minus 10mm.
4. A process as claimed in any one of the preceding claims in which the feed material is dried, calcined, preheated, or pre-reduced, in any combination thereof.
5. A process as claimed in any one of the preceding claims in which the feed material includes recycle slag produced in a downstream converting or refining step for upgrading the unrefined ferronickel product produced by this process.
6. A process as claimed in any one of the preceding claims in which the laterite feed

/material is

material is dried and calcined prior to being fed to the furnace.

7. A process as claimed in claim 6 in which the feed material is milled prior to or following calcining and the milled feed material is subjected to pre-reduction prior to being fed to the furnace.
8. A process as claimed in claim 7 in which the pre-reduction is carried out to an extent at which a portion or substantially all of the Ni is reduced and an incomplete reduction of iron oxides is achieved.
9. A process as claimed in either of claims 7 or 8 in which the prereduction is carried out in a fluidised reduction reactor using gaseous reductants or gases generated from solid reductants combusted in the reactor.
10. A process as claimed in any one of claims 6 to 9 in which drying is carried out at a temperature of about 150°C; calcining at about

/700 - 800°C, and

700 - 800°C, and prereduction at a temperature of about 800 - 850°C.

11. A process as claimed in any one of the preceding claims in which the electrodes situated in the roof of the furnace are graphite electrodes.
12. A process as claimed in any one of the preceding claims in which there is only one centrally located electrode in the roof of the furnace.
13. A process as claimed in any one of the preceding claims in which one or more electrodes situated in the roof of the furnace is or are hollow and feed material is fed to the molten bath by way of such electrode or electrodes.
14. A process as claimed in any one of the preceding claims in which air is excluded in the interior of the furnace and the furnace is

/operated at

operated at a slight positive pressure to enhance such exclusion.

15. A process as claimed in any one of the preceding claims in which the furnace is a plasma d.c arc furnace.
16. A process substantially as herein described and exemplified.

DATED THIS 12th DAY OF AUGUST, 1994.

JOHN & KERNICK

FOR THE APPLICANT

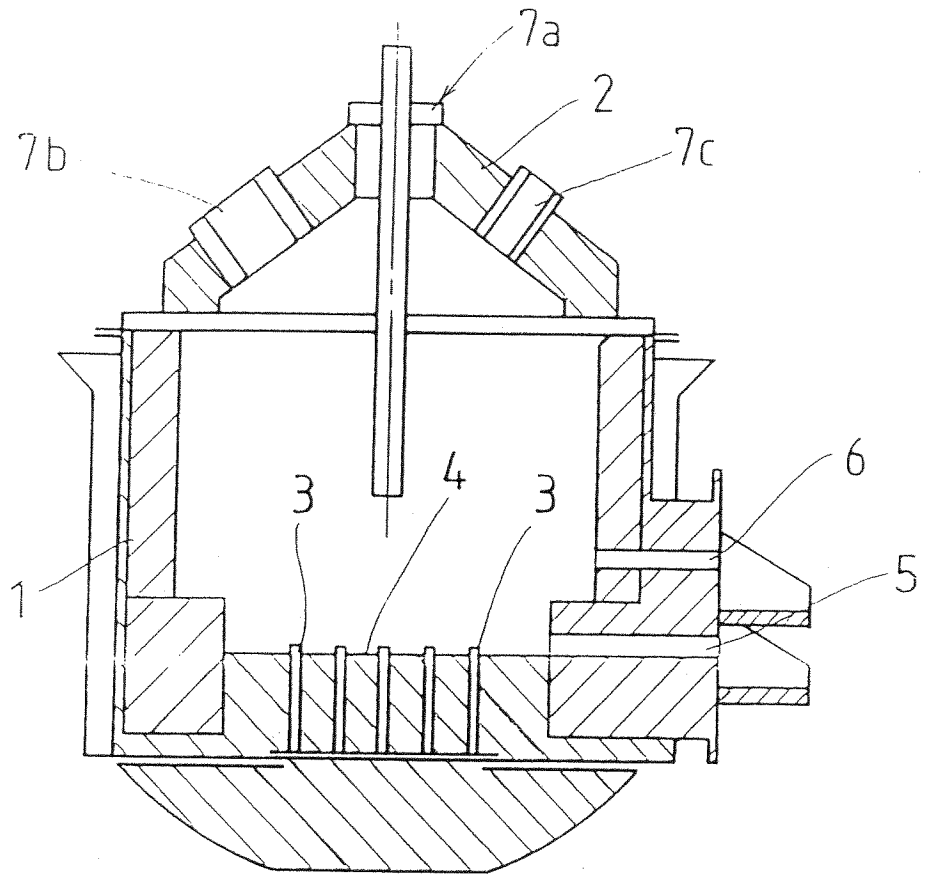

FIG. 1

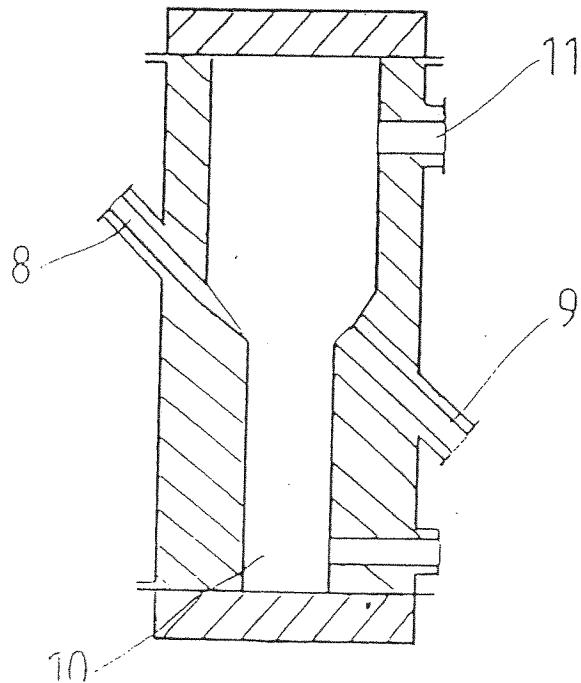

FIG. 2